

XANA floor lamp – piantana

Edmondo Testaguzza design

stake included h33 – *picchetto* **HP260 1B EXT**
stake included h18 – *picchetto* **HP260 7B EXT**

2021

A - LAMP *corpo lampada* matt white aluminum – *alluminio bianco opaco*

B - SHADE *diffusore* frosted glass – *vetro satinato*

C - ELECTRICAL CABLE *cavo elettrico* black 3 meters – *3 metri nero*

OPTIONAL *accessorio* 18W power supply – *alimentatore AC211A2 INT*

ELECTRICAL SYSTEM LED CC, 7,4W, 958 lm, 3000K, CRI≥90 class

PACKAGING *imballo* 15x20x160 cm

NET WEIGHT *peso netto* 0,8 KG

GROSS WEIGHT *peso lordo* 2,1 KG

IP RATE *grado protezione* IP65

CERTIFICATION *conformità* IEC 60598-1:2014 EN 60598-1:2015

EMISSION *emissione* unidirectional – *unidirezionale*

 direct – *diretta*

 filtered – *filtrata*

 indirect – *indiretta*

 none – *assente*

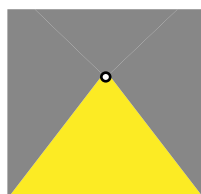

BEWARE: Extra low voltage lamp, power supply necessary
ATTENZIONE: Lampada bassissima tensione, necessario alimentatore



COLLECTION *collezione*

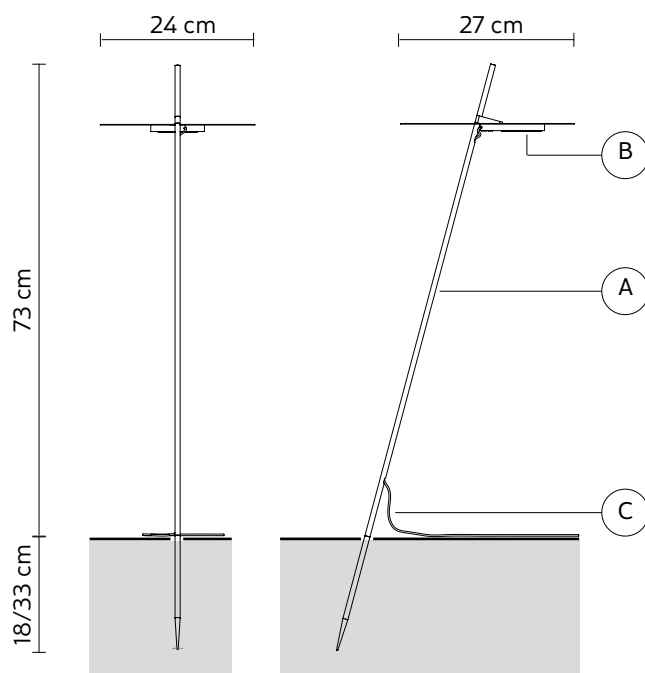
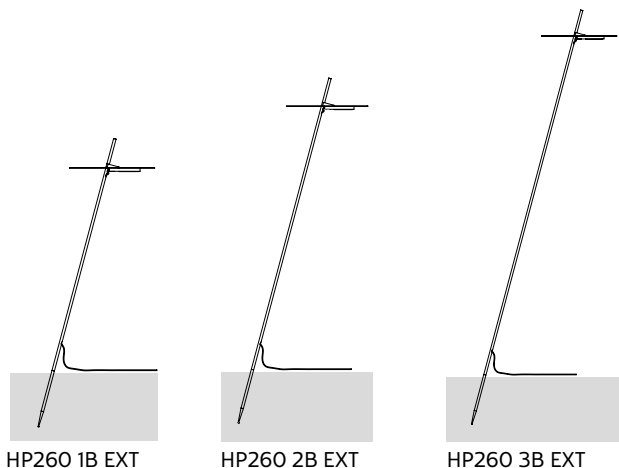

XANA floor lamp – piantana

Edmondo Testaguzza design

stake included h33 – *picchetto* **HP260 1V EXT**
stake included h18 – *picchetto* **HP260 7V EXT**

2021

A - LAMP *corpo lampada* matt green aluminum – *alluminio verde opaco*

B - SHADE *diffusore* frosted glass – *vetro satinato*

C - ELECTRICAL CABLE *cavo elettrico* black 3 meters – *3 metri nero*

OPTIONAL *accessorio* 18W power supply – *alimentatore* **AC211A2 INT**

ELECTRICAL SYSTEM LED CC, 7,4W, 958 lm, 3000K, CRI≥90 class

PACKAGING *imballo* 5x30x160 cm

NET WEIGHT *peso netto* 0,8 KG

GROSS WEIGHT *peso lordo* 2,1 KG

IP RATE *grado protezione* IP65

CERTIFICATION *conformità* IEC 60598-1:2014 EN 60598-1:2015

EMISSION *emissione* unidirectional – *unidirezionale*

 direct – *diretta*

 filtered – *filtrata*

 indirect – *indiretta*

 none – *assente*

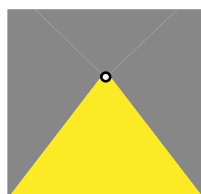

BEWARE: Extra low voltage lamp, power supply necessary
ATTENZIONE: Lampada bassissima tensione, necessario alimentatore



COLLECTION *collezione*

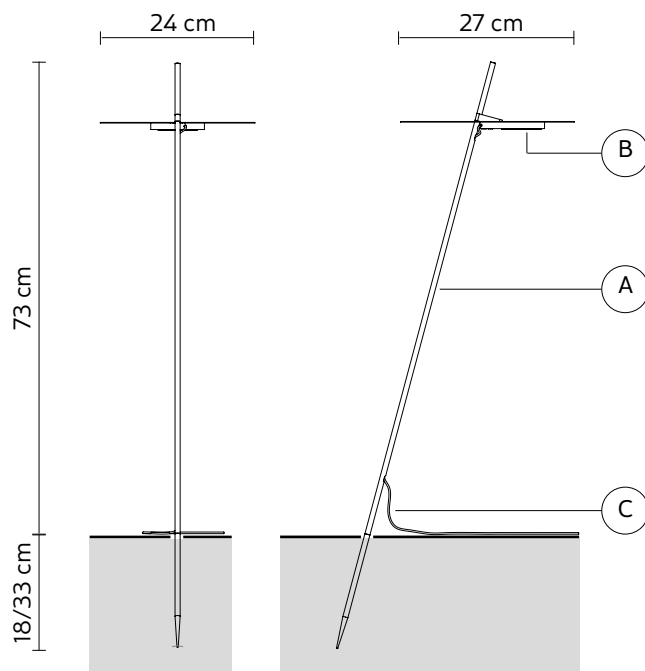
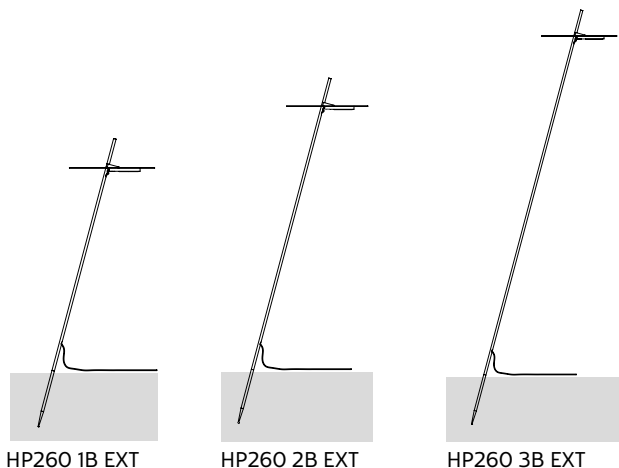

A - LAMP *corpo lampada* matt white aluminum – *alluminio bianco opaco*

B - SHADE *diffusore* frosted glass – *vetro satinato*

C - ELECTRICAL CABLE *cavo elettrico* black 3 meters – *3 metri nero*

OPTIONAL *accessorio* 18W power supply – *alimentatore* **AC211A2 INT**

ELECTRICAL SYSTEM LED CC, 7,4W, 958 lm, 3000K, CRI≥90 class A+

PACKAGING *imballo* 15x20x160 cm





NET WEIGHT *peso netto* 0,9 KG

GROSS WEIGHT *peso lordo* 2,2 KG

IP RATE *grado protezione* IP65

CERTIFICATION *conformità* IEC 60598-1:2014 EN 60598-1:2015

EMISSION *emissione* unidirectional – *unidirezionale*

-  direct – *diretta*
-  filtered – *filtrata*
-  indirect – *indiretta*
-  none – *assente*

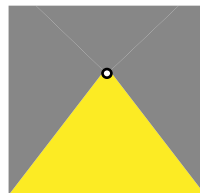

BEWARE: Extra low voltage lamp, power supply necessary
ATTENZIONE: Lampada bassissima tensione, necessario alimentatore



COLLECTION *collezione*

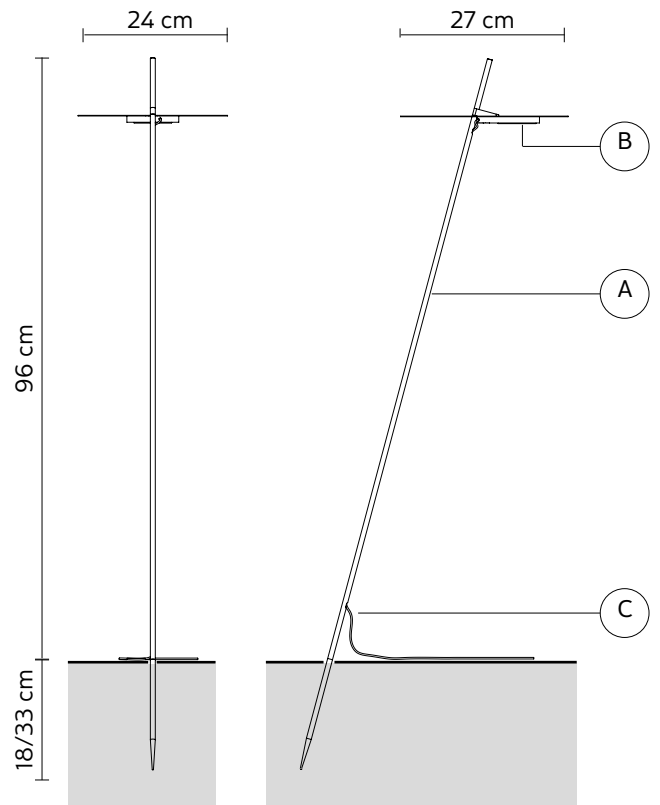
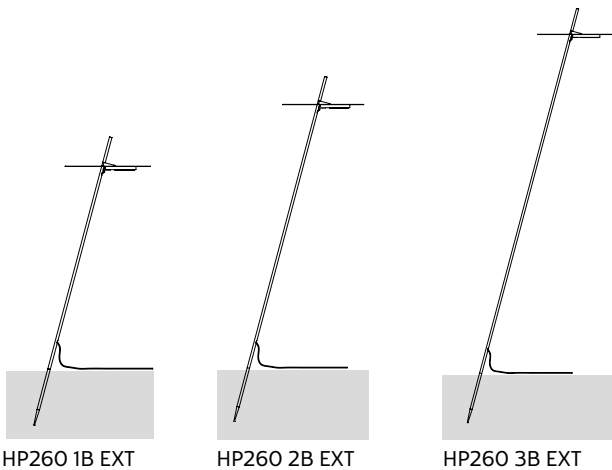

XANA floor lamp – piantana

stake included h33 – *picchetto* **HP260 2V EXT**
stake included h18 – *picchetto* **HP260 8V EXT**

Edmondo Testaguzza design

2021

A - LAMP *corpo lampada* matt green aluminum – *alluminio verde opaco*

B - SHADE *diffusore* frosted glass – *vetro satinato*

C - ELECTRICAL CABLE *cavo elettrico* black 3 meters – *3 metri nero*

OPTIONAL *accessorio* 18W power supply – *alimentatore* **AC211A2 INT**

ELECTRICAL SYSTEM LED CC, 7,4W, 958 lm, 3000K, CRI≥90 class A+

PACKAGING *imballo* 5x30x160 cm





NET WEIGHT *peso netto* 0,9 KG

GROSS WEIGHT *peso lordo* 2,2 KG

IP RATE *grado protezione* IP65

CERTIFICATION *conformità* IEC 60598-1:2014 EN 60598-1:2015

EMISSION *emissione* unidirectional – *unidirezionale*

-  direct – *diretta*
-  filtered – *filtrata*
-  indirect – *indiretta*
-  none – *assente*

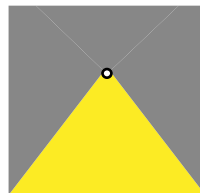

BEWARE: Extra low voltage lamp, power supply necessary
ATTENZIONE: Lampada bassissima tensione, necessario alimentatore



COLLECTION *collezione*

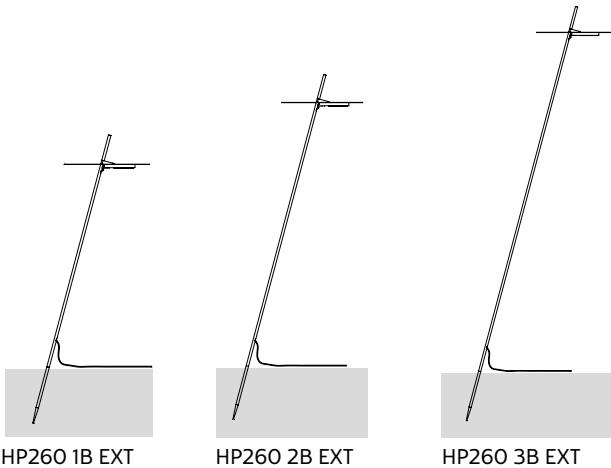

HP260 1B EXT

HP260 2B EXT

HP260 3B EXT

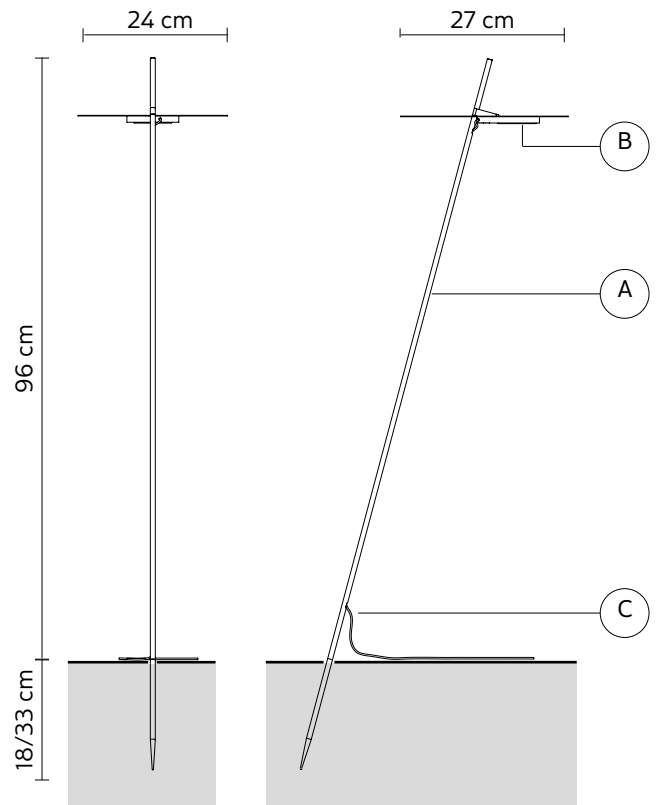

XANA floor lamp – piantana

stake included h33 – *picchetto* **HP260 3B EXT**
stake included h18 – *picchetto* **HP260 9B EXT**

Edmondo Testaguzza design

2021

A - LAMP *corpo lampada* matt white aluminum – *alluminio bianco opaco*

B - SHADE *diffusore* frosted glass – *vetro satinato*

C - ELECTRICAL CABLE *cavo elettrico* black 3 meters – *3 metri nero*

OPTIONAL *accessorio* 18W power supply – *alimentatore* **AC211A2 INT**

ELECTRICAL SYSTEM LED CC, 7,4W, 958 lm, 3000K, CRI≥90 class A+

PACKAGING *imballo* 15x20x220 cm

NET WEIGHT *peso netto* 1,1 KG

GROSS WEIGHT *peso lordo* 2,4 KG

IP RATE *grado protezione* IP65

CERTIFICATION *conformità* IEC 60598-1:2014 EN 60598-1:2015

EMISSION *emissione* unidirectional – *unidirezionale*

 direct – *diretta*

 filtered – *filtrata*

 indirect – *indiretta*

 none – *assente*

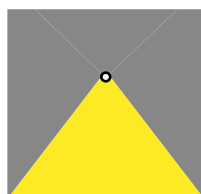

BEWARE: Extra low voltage lamp, power supply necessary
ATTENZIONE: Lampada bassissima tensione, necessario alimentatore



COLLECTION *collezione*

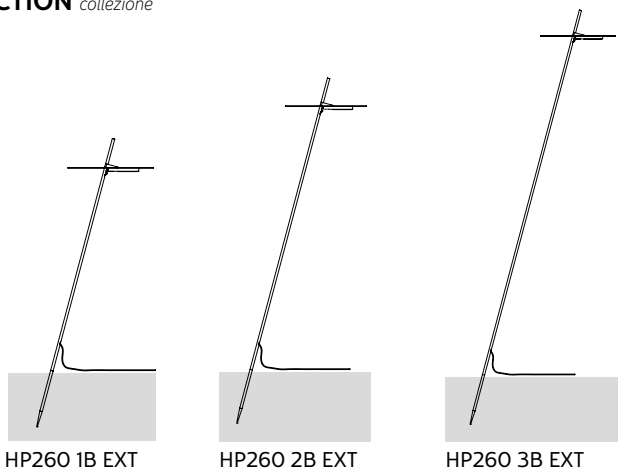

HP260 1B EXT

HP260 2B EXT

HP260 3B EXT

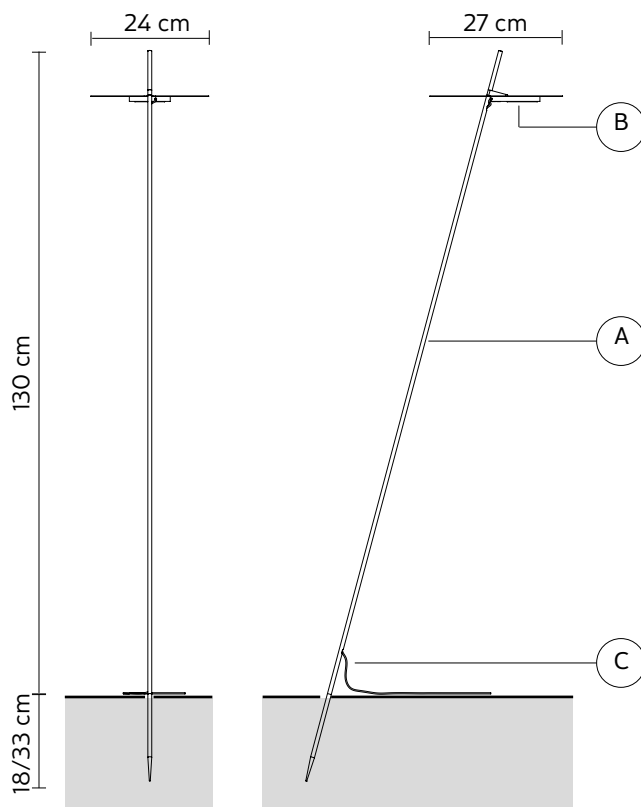

A - LAMP *corpo lampada* matt green aluminum – *alluminio verde opaco*

B - SHADE *diffusore* frosted glass – *vetro satinato*

C - ELECTRICAL CABLE *cavo elettrico* black 3 meters – *3 metri nero*

OPTIONAL *accessorio* 18W power supply – *alimentatore* **AC211A2 INT**

ELECTRICAL SYSTEM LED CC, 7,4W, 958 lm, 3000K, CRI≥90 class A+

PACKAGING *imballo* 5x30x160 cm





NET WEIGHT *peso netto* 1,1 KG

GROSS WEIGHT *peso lordo* 2,4 KG

IP RATE *grado protezione* IP65

CERTIFICATION *conformità* IEC 60598-1:2014 EN 60598-1:2015

EMISSION *emissione* unidirectional – *unidirezionale*

-  direct – *diretta*
-  filtered – *filtrata*
-  indirect – *indiretta*
-  none – *assente*

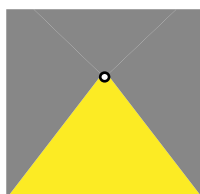

BEWARE: Extra low voltage lamp, power supply necessary
ATTENZIONE: Lampada bassissima tensione, necessario alimentatore



COLLECTION *collezione*

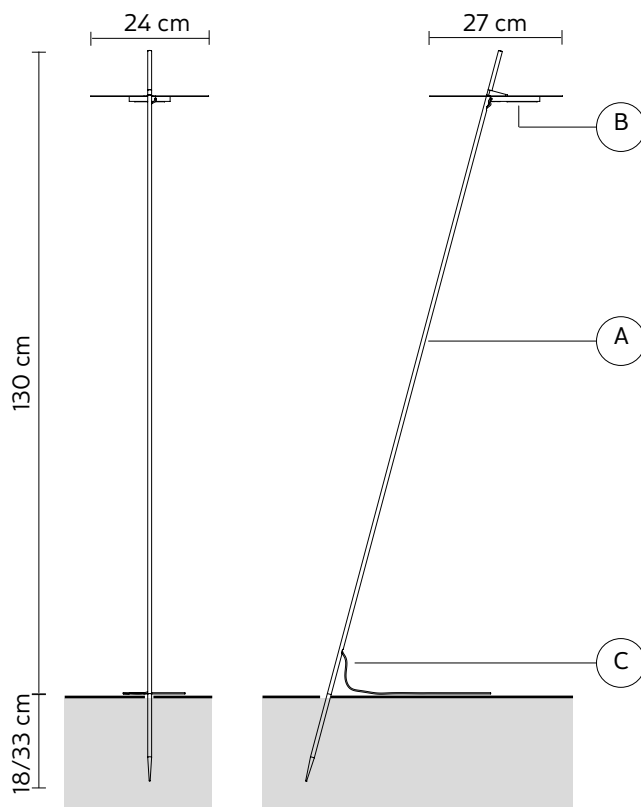
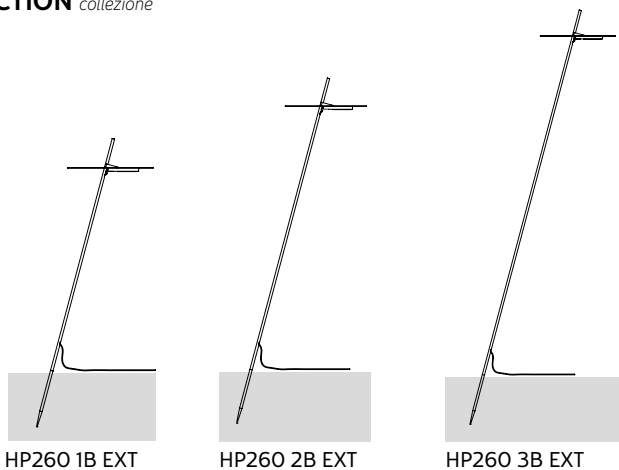

XANA floor lamp – piantana

Edmondo Testaguzza design

HP260 4B EXT

2021

A - LAMP *corpo lampada* matt white aluminum – alluminio bianco opaco

B - SHADE *diffusore* frosted glass – vetro satinato

C - ELECTRICAL CABLE *cavo elettrico* black 20cm – 20cm nero

OPTIONAL *accessorio* 18W power supply – alimentatore **AC211A2 INT**

ELECTRICAL SYSTEM LED CC, 7,4W, 958 lm, 3000K, CRI≥90 class A+

PACKAGING *imballo* 15x20x160 cm

NET WEIGHT *peso netto* 0,8 KG

GROSS WEIGHT *peso lordo* 2,1 KG

IP RATE *grado protezione* IP65

CERTIFICATION *conformità* IEC 60598-1:2014 EN 60598-1:2015

EMISSION *emissione* unidirectional – unidirezionale

 direct – diretta

 filtered – filtrata

 indirect – indiretta

 none – assente

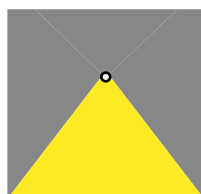

BEWARE: Extra low voltage lamp, power supply necessary

ATTENZIONE: Lampada bassissima tensione, necessario alimentatore



COLLECTION *collezione*

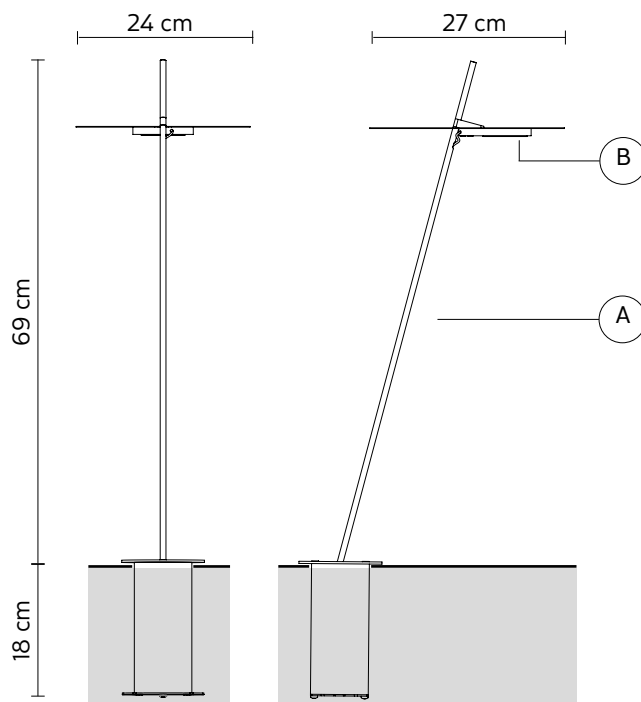
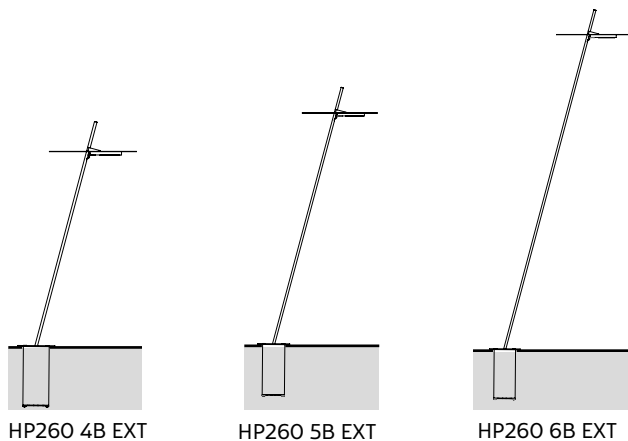

A - LAMP *corpo lampada* matt green aluminum - alluminio verde opaco

B - SHADE *diffusore* frosted glass - vetro satinato

C - ELECTRICAL CABLE *cavo elettrico* black 20cm - 20cm nero

OPTIONAL *accessorio* 18W power supply - alimentatore **AC211A2 INT**

ELECTRICAL SYSTEM LED CC, 7,4W, 958 lm, 3000K, CRI≥90 class A+

PACKAGING *imballo* 10x50x160 cm





NET WEIGHT *peso netto* 0,8 KG

GROSS WEIGHT *peso lordo* 2,1 KG

IP RATE *grado protezione* IP65

CERTIFICATION *conformità* IEC 60598-1:2014 EN 60598-1:2015

EMISSION *emissione* unidirectional - unidirezionale

-  direct - diretta
-  filtered - filtrata
-  indirect - indiretta
-  none - assente

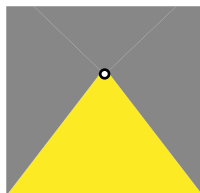

BEWARE: Extra low voltage lamp, power supply necessary
ATTENZIONE: Lampada bassissima tensione, necessario alimentatore



COLLECTION *collezione*

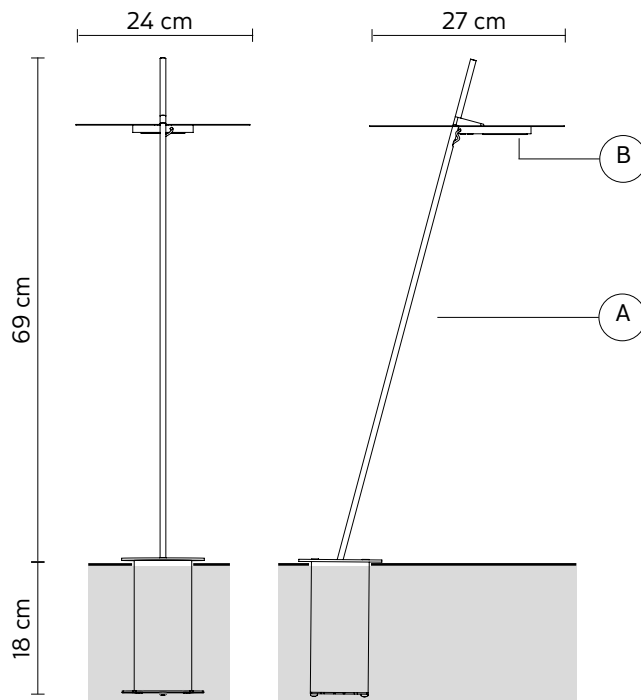
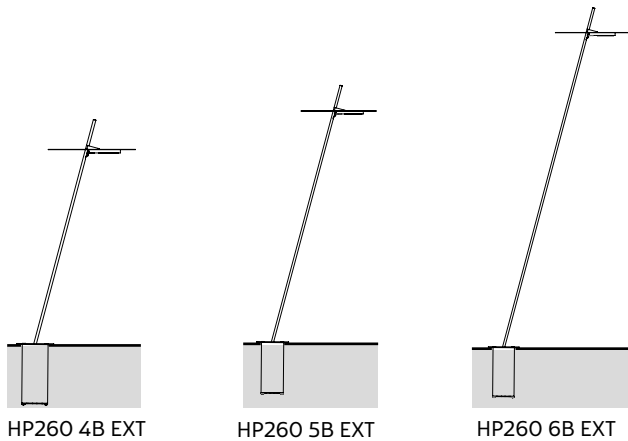

A - LAMP *corpo lampada* matt white aluminum – alluminio bianco opaco

B - SHADE *diffusore* frosted glass – vetro satinato

C - ELECTRICAL CABLE *cavo elettrico* black 20cm – 20cm nero

OPTIONAL *accessorio* 18W power supply – alimentatore **AC211A2 INT**

ELECTRICAL SYSTEM LED CC, 7,4W, 958 lm, 3000K, CRI≥90 class A+

PACKAGING *imballo* 15x20x160 cm

NET WEIGHT *peso netto* 0,9 KG

GROSS WEIGHT *peso lordo* 2,2 KG

IP RATE *grado protezione* IP65

CERTIFICATION *conformità* IEC 60598-1:2014 EN 60598-1:2015

EMISSION *emissione* unidirectional – unidirezionale

 direct – diretta

 filtered – filtrata

 indirect – indiretta

 none – assente

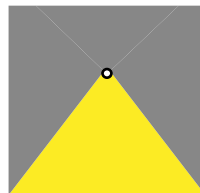

BEWARE: Extra low voltage lamp, power supply necessary
ATTENZIONE: Lampada bassissima tensione, necessario alimentatore



COLLECTION *collezione*

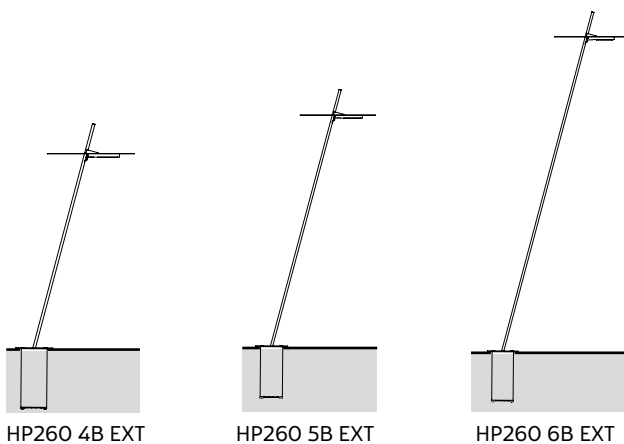

HP260 4B EXT

HP260 5B EXT

HP260 6B EXT

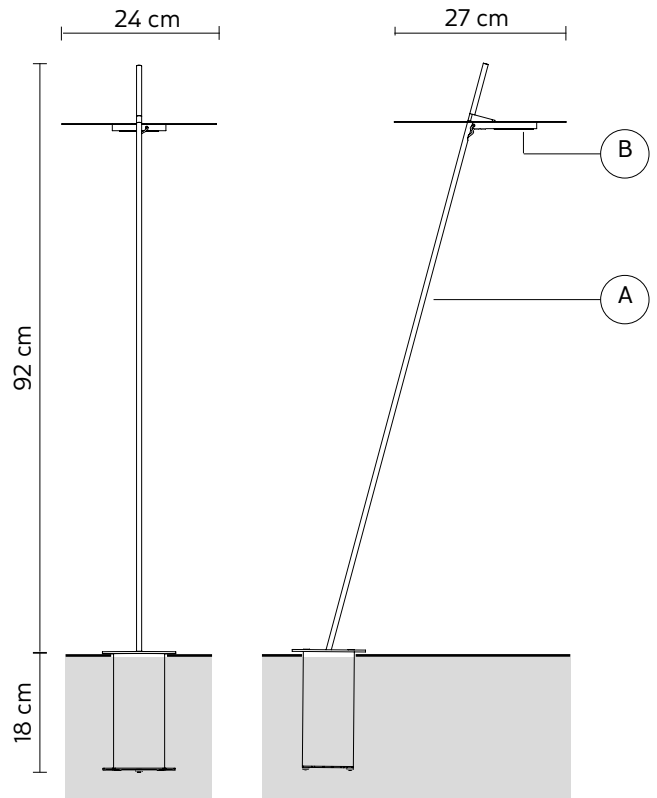

A - LAMP *corpo lampada* matt green aluminum - *alluminio verde opaco*

B - SHADE *diffusore* frosted glass - *vetro satinato*

C - ELECTRICAL CABLE *cavo elettrico* black 20cm - *20cm nero*

OPTIONAL *accessorio* 18W power supply - *alimentatore* **AC211A2 INT**

ELECTRICAL SYSTEM LED CC, 7,4W, 958 lm, 3000K, CRI≥90 class A+

PACKAGING *imballo* 10x50x160 cm

NET WEIGHT *peso netto* 0,9 KG

GROSS WEIGHT *peso lordo* 2,2 KG

IP RATE *grado protezione* IP65

CERTIFICATION *conformità* IEC 60598-1:2014 EN 60598-1:2015

EMISSION *emissione* unidirectional - *unidirezionale*

 direct - *diretta*

 filtered - *filtrata*

 indirect - *indiretta*

 none - *assente*

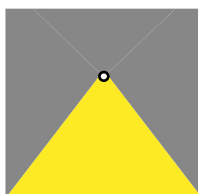

BEWARE: Extra low voltage lamp, power supply necessary
ATTENZIONE: Lampada bassissima tensione, necessario alimentatore



COLLECTION *collezione*

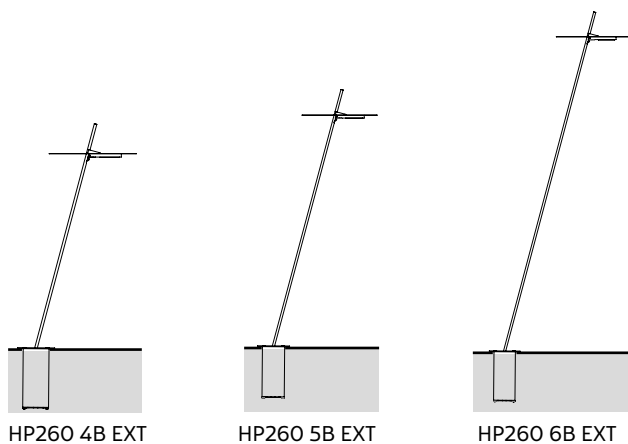

HP260 4B EXT

HP260 5B EXT

HP260 6B EXT

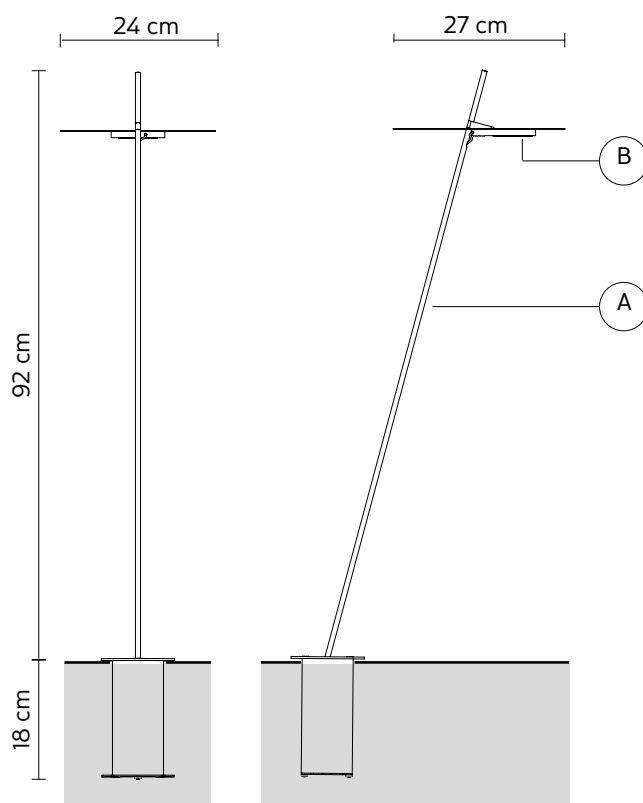

A - LAMP *corpo lampada* matt white aluminum – alluminio bianco opaco

B - SHADE *diffusore* frosted glass – vetro satinato

ELECTRICAL CABLE *cavo elettrico* black 20cm – 20cm nero

OPTIONAL *accessorio* 18W power supply – alimentatore **AC211A2 INT**

ELECTRICAL SYSTEM LED CC, 7,4W, 958 lm, 3000K, CRI≥90 class A+

PACKAGING *imballo* 15x20x220 cm

NET WEIGHT *peso netto* 1,2 KG

GROSS WEIGHT *peso lordo* 2,6 KG

IP RATE *grado protezione* IP65

CERTIFICATION *conformità* IEC 60598-1:2014 EN 60598-1:2015

EMISSION *emissione* unidirectional – unidirezionale

 direct – diretta

 filtered – filtrata

 indirect – indiretta

 none – assente

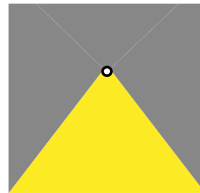

BEWARE: Extra low voltage lamp, power supply necessary
ATTENZIONE: Lampada bassissima tensione, necessario alimentatore



COLLECTION *collezione*

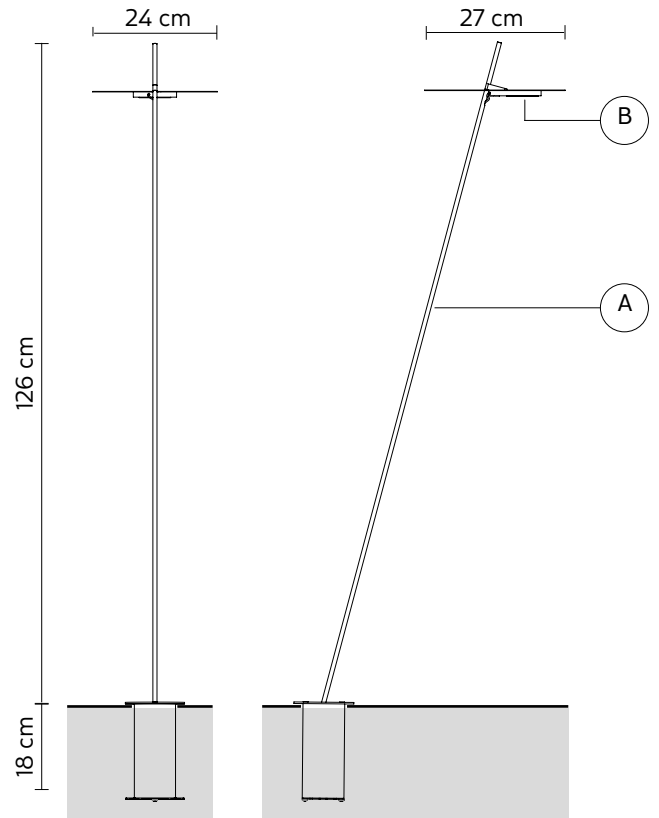
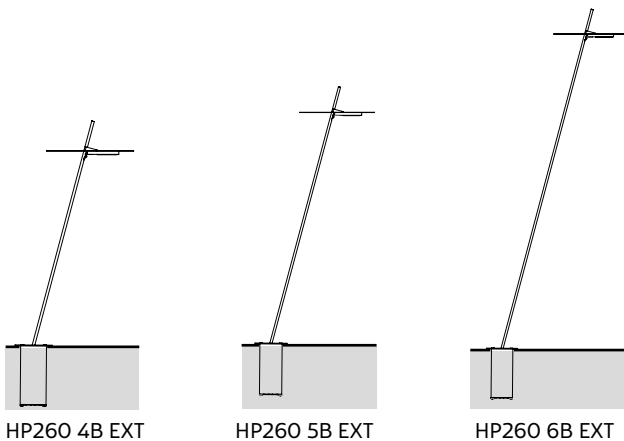

A - LAMP *corpo lampada* matt green aluminum - *alluminio verde opaco*

B - SHADE *diffusore* frosted glass - *vetro satinato*

ELECTRICAL CABLE *cavo elettrico* black 20cm - *20cm nero*

OPTIONAL *accessorio* 18W power supply - *alimentatore* **AC211A2 INT**

ELECTRICAL SYSTEM LED CC, 7,4W, 958 lm, 3000K, CRI≥90 class A+

PACKAGING *imballo* 10x50x160 cm

NET WEIGHT *peso netto* 1,2 KG

GROSS WEIGHT *peso lordo* 2,6 KG

IP RATE *grado protezione* IP65

CERTIFICATION *conformità* IEC 60598-1:2014 EN 60598-1:2015

EMISSION *emissione* unidirectional - *unidirezionale*

 direct - *diretta*

 filtered - *filtrata*

 indirect - *indiretta*

 none - *assente*

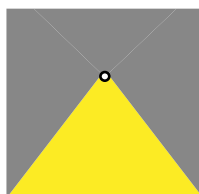

BEWARE: Extra low voltage lamp, power supply necessary
ATTENZIONE: Lampada bassissima tensione, necessario alimentatore



COLLECTION *collezione*

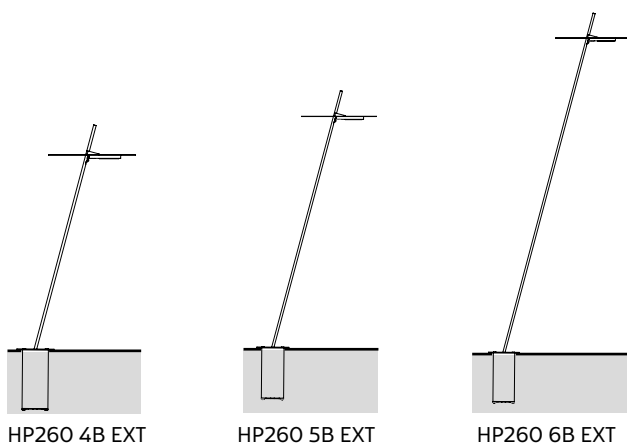

HP260 4B EXT

HP260 5B EXT

HP260 6B EXT

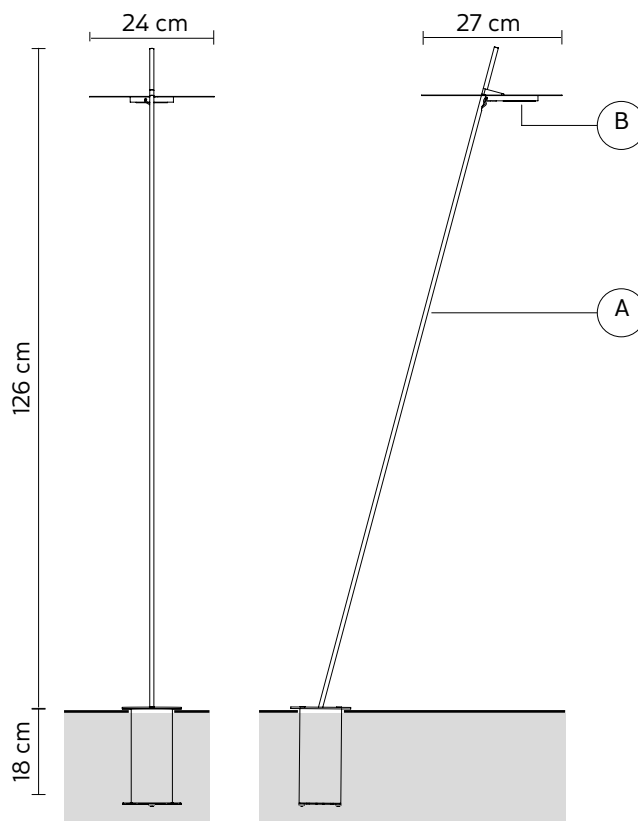

XANA floor lamp – piantana

Edmondo Testaguzza design

stake included h33 – *picchetto* **HP260 1B EXT**
stake included h18 – *picchetto* **HP260 7B EXT**

2021

A - LAMP *corpo lampada* matt white aluminum – *alluminio bianco opaco*

B - SHADE *diffusore* frosted glass – *vetro satinato*

C - ELECTRICAL CABLE *cavo elettrico* black 3 meters – *3 metri nero*

OPTIONAL *accessorio* 18W power supply – *alimentatore AC211A2 INT*

ELECTRICAL SYSTEM LED CC, 7,4W, 958 lm, 3000K, CRI≥90 class

PACKAGING *imballo* 15x20x160 cm

NET WEIGHT *peso netto* 0,8 KG

GROSS WEIGHT *peso lordo* 2,1 KG

IP RATE *grado protezione* IP65

CERTIFICATION *conformità* IEC 60598-1:2014 EN 60598-1:2015

EMISSION *emissione* unidirectional – *unidirezionale*

 direct – *diretta*

 filtered – *filtrata*

 indirect – *indiretta*

 none – *assente*

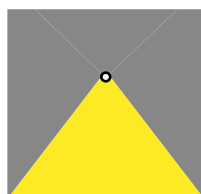

BEWARE: Extra low voltage lamp, power supply necessary
ATTENZIONE: Lampada bassissima tensione, necessario alimentatore



COLLECTION *collezione*

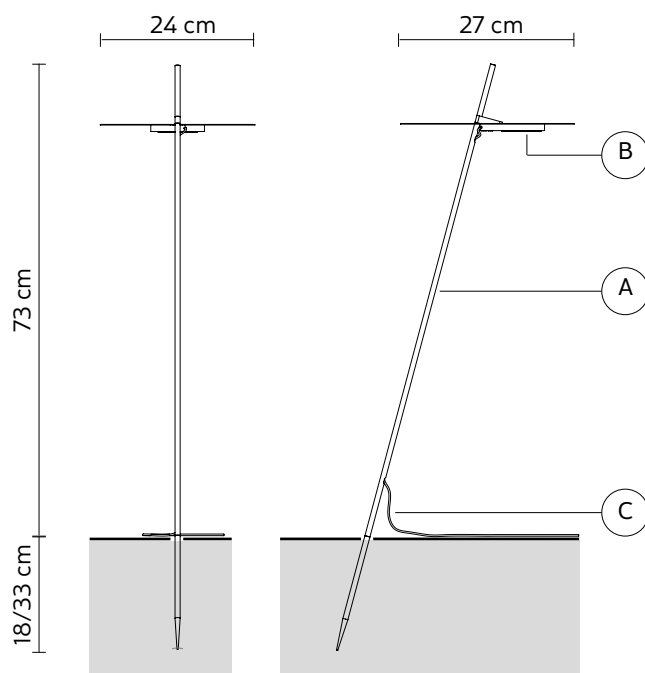
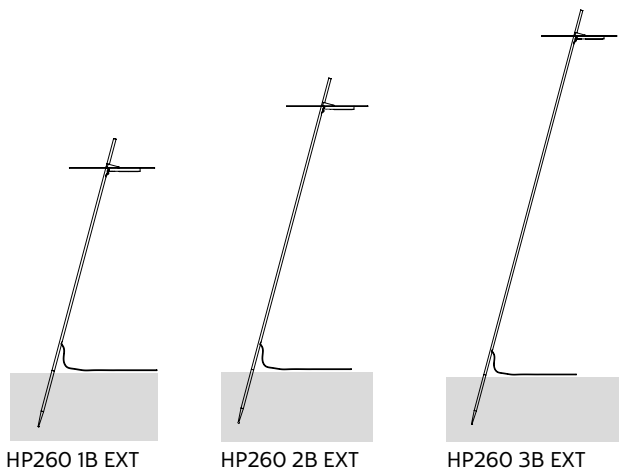

XANA floor lamp – piantana

Edmondo Testaguzza design

stake included h33 – *picchetto* **HP260 1V EXT**
stake included h18 – *picchetto* **HP260 7V EXT**

2021

A - LAMP *corpo lampada* matt green aluminum – *alluminio verde opaco*

B - SHADE *diffusore* frosted glass – *vetro satinato*

C - ELECTRICAL CABLE *cavo elettrico* black 3 meters – *3 metri nero*

OPTIONAL *accessorio* 18W power supply – *alimentatore* **AC211A2 INT**

ELECTRICAL SYSTEM LED CC, 7,4W, 958 lm, 3000K, CRI≥90 class

PACKAGING *imballo* 5x30x160 cm

NET WEIGHT *peso netto* 0,8 KG

GROSS WEIGHT *peso lordo* 2,1 KG

IP RATE *grado protezione* IP65

CERTIFICATION *conformità* IEC 60598-1:2014 EN 60598-1:2015

EMISSION *emissione* unidirectional – *unidirezionale*

 direct – *diretta*

 filtered – *filtrata*

 indirect – *indiretta*

 none – *assente*

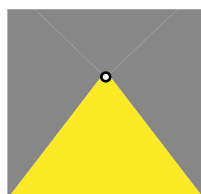

BEWARE: Extra low voltage lamp, power supply necessary
ATTENZIONE: Lampada bassissima tensione, necessario alimentatore



COLLECTION *collezione*

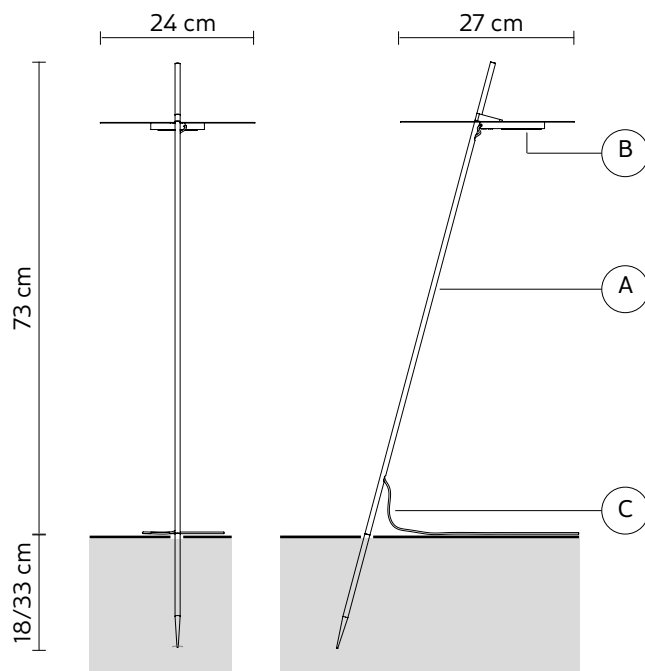
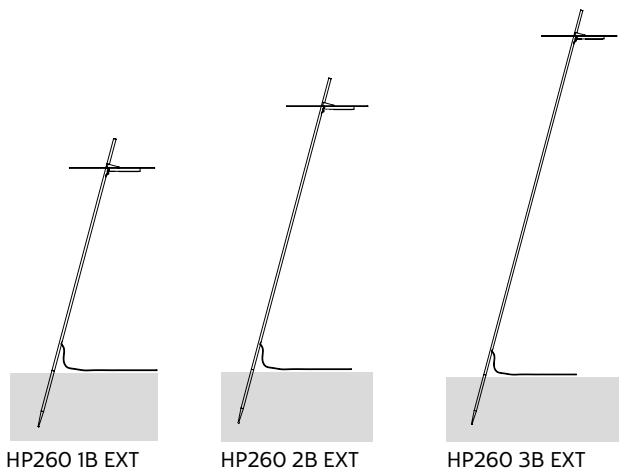

A - LAMP *corpo lampada* matt white aluminum – *alluminio bianco opaco*

B - SHADE *diffusore* frosted glass – *vetro satinato*

C - ELECTRICAL CABLE *cavo elettrico* black 3 meters – *3 metri nero*

OPTIONAL *accessorio* 18W power supply – *alimentatore* **AC211A2 INT**

ELECTRICAL SYSTEM LED CC, 7,4W, 958 lm, 3000K, CRI≥90 class A+

PACKAGING *imballo* 15x20x160 cm





NET WEIGHT *peso netto* 0,9 KG

GROSS WEIGHT *peso lordo* 2,2 KG

IP RATE *grado protezione* IP65

CERTIFICATION *conformità* IEC 60598-1:2014 EN 60598-1:2015

EMISSION *emissione* unidirectional – *unidirezionale*

-  direct – *diretta*
-  filtered – *filtrata*
-  indirect – *indiretta*
-  none – *assente*

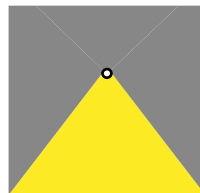

BEWARE: Extra low voltage lamp, power supply necessary
ATTENZIONE: Lampada bassissima tensione, necessario alimentatore



COLLECTION *collezione*

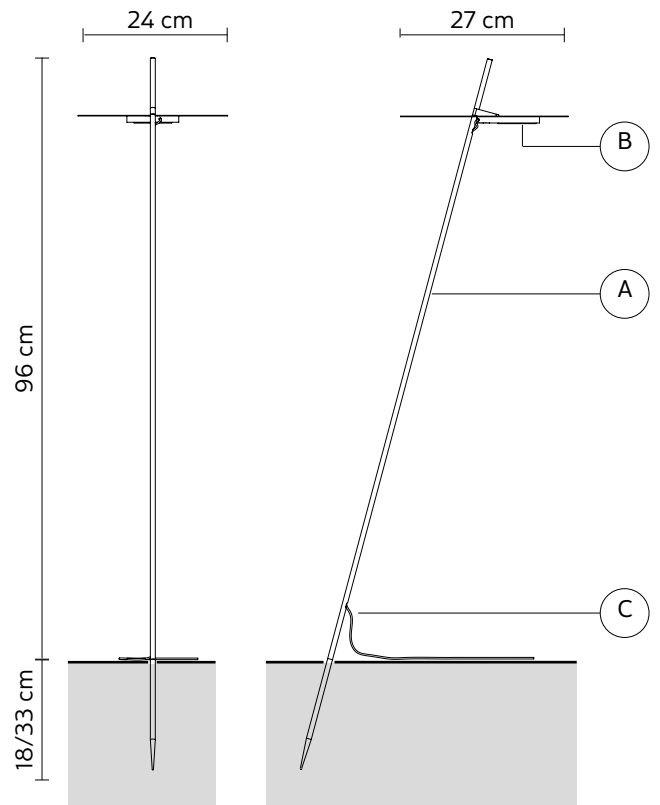
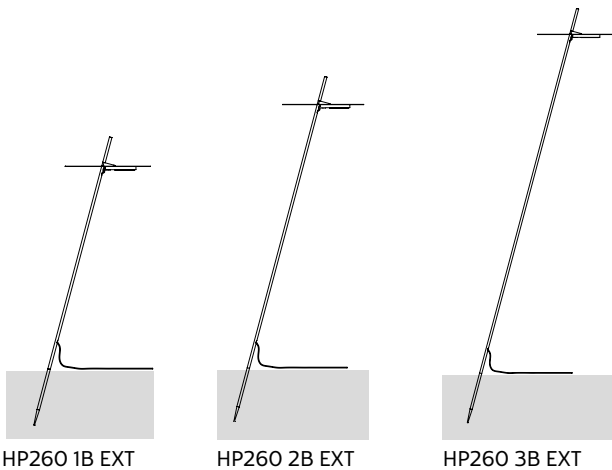

XANA floor lamp – piantana

stake included h33 – *picchetto* **HP260 2V EXT**
stake included h18 – *picchetto* **HP260 8V EXT**

Edmondo Testaguzza design

2021

A - LAMP *corpo lampada* matt green aluminum – *alluminio verde opaco*

B - SHADE *diffusore* frosted glass – *vetro satinato*

C - ELECTRICAL CABLE *cavo elettrico* black 3 meters – *3 metri nero*

OPTIONAL *accessorio* 18W power supply – *alimentatore* **AC211A2 INT**

ELECTRICAL SYSTEM LED CC, 7,4W, 958 lm, 3000K, CRI≥90 class A+

PACKAGING *imballo* 5x30x160 cm





NET WEIGHT *peso netto* 0,9 KG

GROSS WEIGHT *peso lordo* 2,2 KG

IP RATE *grado protezione* IP65

CERTIFICATION *conformità* IEC 60598-1:2014 EN 60598-1:2015

EMISSION *emissione* unidirectional – *unidirezionale*

-  direct – *diretta*
-  filtered – *filtrata*
-  indirect – *indiretta*
-  none – *assente*

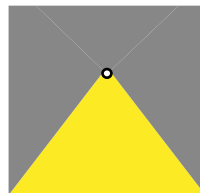

BEWARE: Extra low voltage lamp, power supply necessary
ATTENZIONE: Lampada bassissima tensione, necessario alimentatore



COLLECTION *collezione*

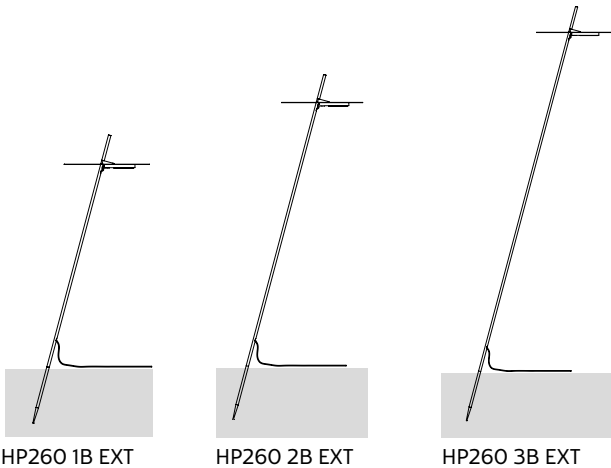

HP260 1B EXT

HP260 2B EXT

HP260 3B EXT

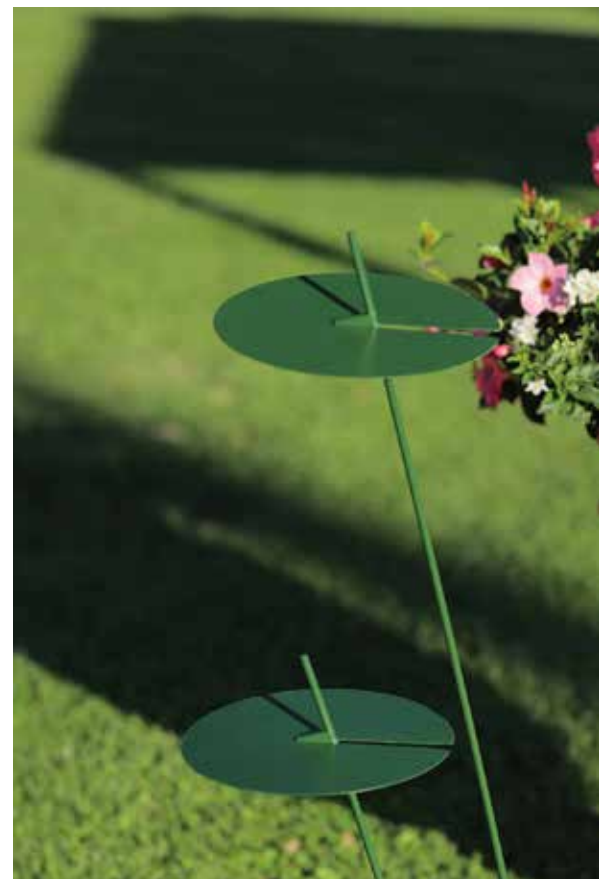
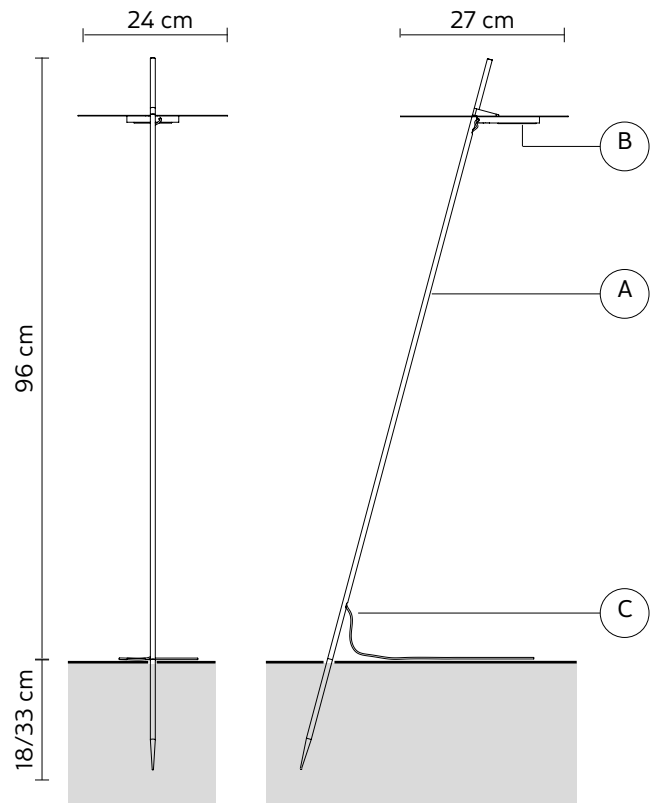

XANA floor lamp – piantana

stake included h33 – *picchetto* **HP260 3B EXT**
stake included h18 – *picchetto* **HP260 9B EXT**

Edmondo Testaguzza design

2021

A - LAMP *corpo lampada* matt white aluminum – *alluminio bianco opaco*

B - SHADE *diffusore* frosted glass – *vetro satinato*

C - ELECTRICAL CABLE *cavo elettrico* black 3 meters – *3 metri nero*

OPTIONAL *accessorio* 18W power supply – *alimentatore* **AC211A2 INT**

ELECTRICAL SYSTEM LED CC, 7,4W, 958 lm, 3000K, CRI≥90 class A+

PACKAGING *imballo* 15x20x220 cm

NET WEIGHT *peso netto* 1,1 KG

GROSS WEIGHT *peso lordo* 2,4 KG

IP RATE *grado protezione* IP65

CERTIFICATION *conformità* IEC 60598-1:2014 EN 60598-1:2015

EMISSION *emissione* unidirectional – *unidirezionale*

 direct – *diretta*

 filtered – *filtrata*

 indirect – *indiretta*

 none – *assente*

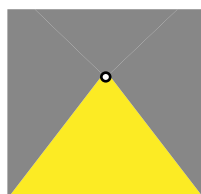

BEWARE: Extra low voltage lamp, power supply necessary
ATTENZIONE: Lampada bassissima tensione, necessario alimentatore



COLLECTION *collezione*

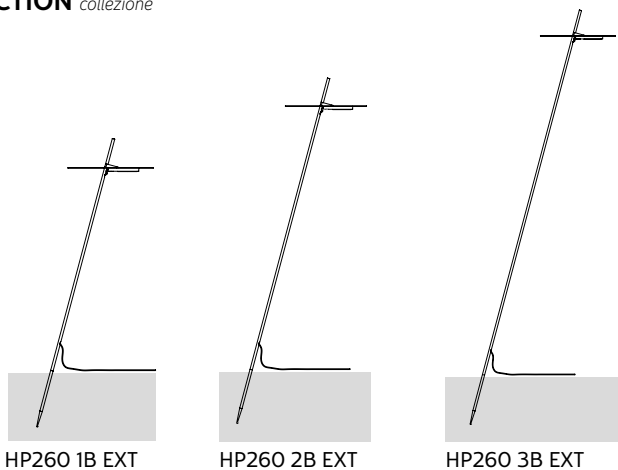

HP260 1B EXT

HP260 2B EXT

HP260 3B EXT

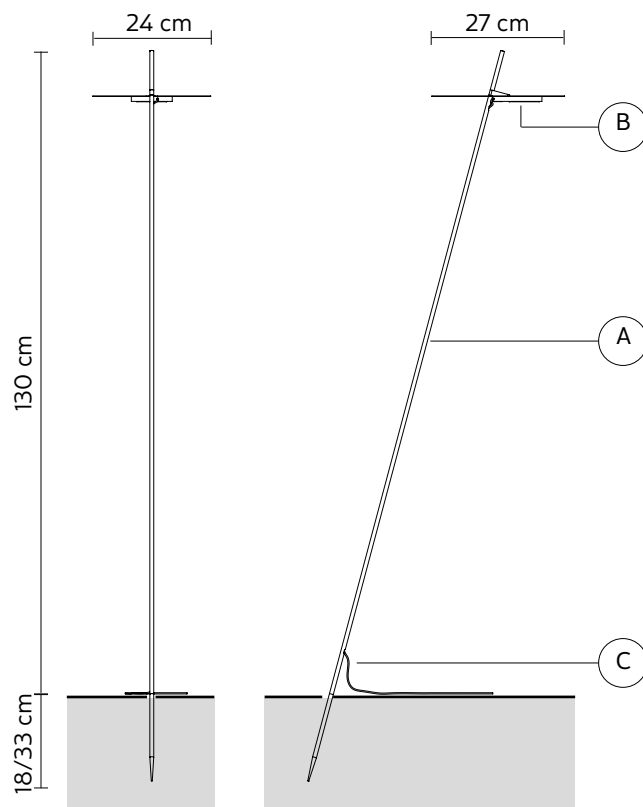

A - LAMP *corpo lampada* matt green aluminum – *alluminio verde opaco*

B - SHADE *diffusore* frosted glass – *vetro satinato*

C - ELECTRICAL CABLE *cavo elettrico* black 3 meters – *3 metri nero*

OPTIONAL *accessorio* 18W power supply – *alimentatore* **AC211A2 INT**

ELECTRICAL SYSTEM LED CC, 7,4W, 958 lm, 3000K, CRI≥90 class A+

PACKAGING *imballo* 5x30x160 cm





NET WEIGHT *peso netto* 1,1 KG

GROSS WEIGHT *peso lordo* 2,4 KG

IP RATE *grado protezione* IP65

CERTIFICATION *conformità* IEC 60598-1:2014 EN 60598-1:2015

EMISSION *emissione* unidirectional – *unidirezionale*

-  direct – *diretta*
-  filtered – *filtrata*
-  indirect – *indiretta*
-  none – *assente*

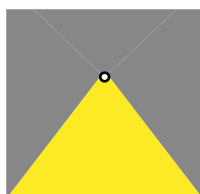

BEWARE: Extra low voltage lamp, power supply necessary
ATTENZIONE: Lampada bassissima tensione, necessario alimentatore



COLLECTION *collezione*

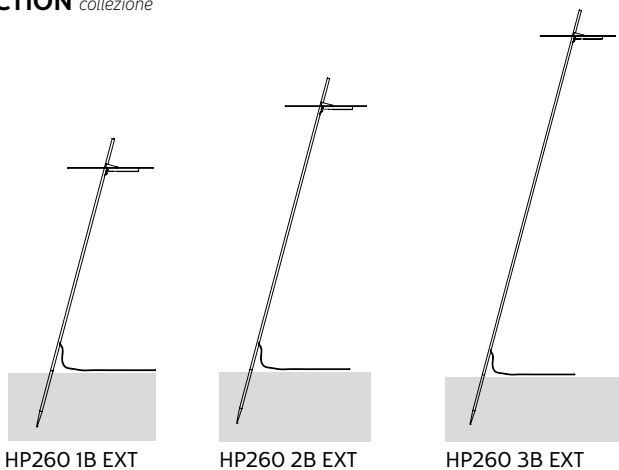

HP260 1B EXT

HP260 2B EXT

HP260 3B EXT

