

# TOBIA floor lamp

Edmondo Testaguzza design

year 2017

## DATA SHEET - HP145 1F EXT

### STRUCTURE "A"

material techno polymer  
colour white



### ELECTRICAL CABLE

colour black



### ELECTRICAL SYSTEM

source LED  
17,2W, 1550lumen, 3000K  
class A+

### PACKAGING

nr. of collis 1  
net weight/kg 3,6  
gross weight/kg 7,5  
packaging/cm 190x40x40

### ACCESSORY WALL HOOK - AC143 4A INT

not provided

material brushed steel



### ACCESSORY FLOOR PEDISTAL - AC143 5A INT

not provided

material steel inox



### EMISSION OF LIGHT

one directional

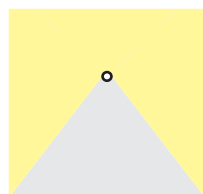

direct  
filtered  
indirect  
none

### CERTIFICATION

IEC 60598-1:2008  
EN 60598-1:2008 + A11:2009



IP rate IP65  
LED equipped

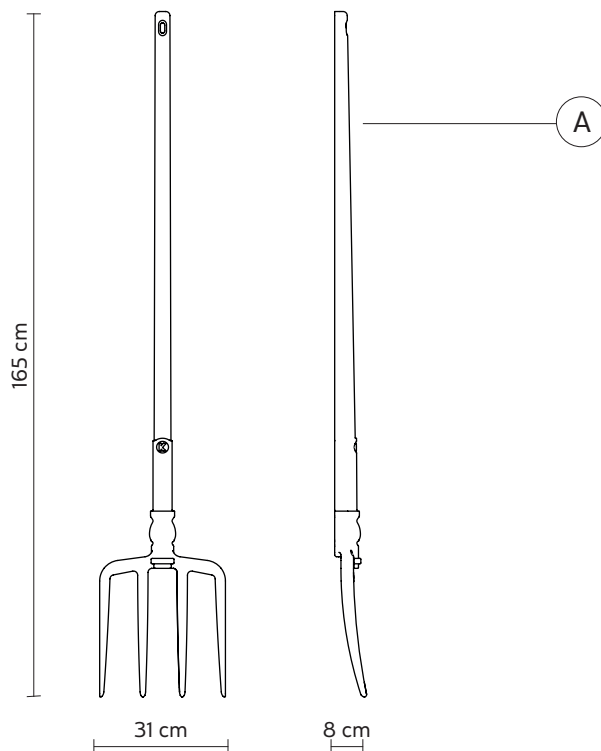

### COLLECTION

available also as: indoor version

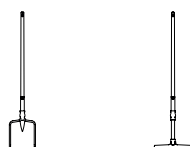

HP145 2P EXT HP145 3R EXT

# TOBIA floor lamp

Edmondo Testaguzza design

year 2017

DATA SHEET - **HP145 1F INT**

## STRUCTURE "A"

material techno polymer  
colour white



## ELECTRICAL CABLE

colour black



## ELECTRICAL SYSTEM

source LED  
17,2W, 1550lumen, 3000K  
class A+

## PACKAGING

nr. of collis 1  
net weight/kg 3,6  
gross weight/kg 7,5  
packaging/cm 190x40x40

## ACCESSORY WALL HOOK - AC143 4A INT

not provided

material brushed steel



## ACCESSORY FLOOR PEDISTAL - AC143 5A INT

not provided





material steel inox

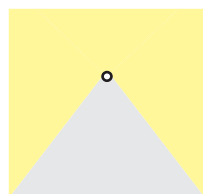

## EMISSION OF LIGHT

one directional



 direct  
 filtered  
 indirect  
 none

## CERTIFICATION

IEC 60598-1:2008  
EN 60598-1:2008 + A11:2009



IP rate IP20  
LED equipped

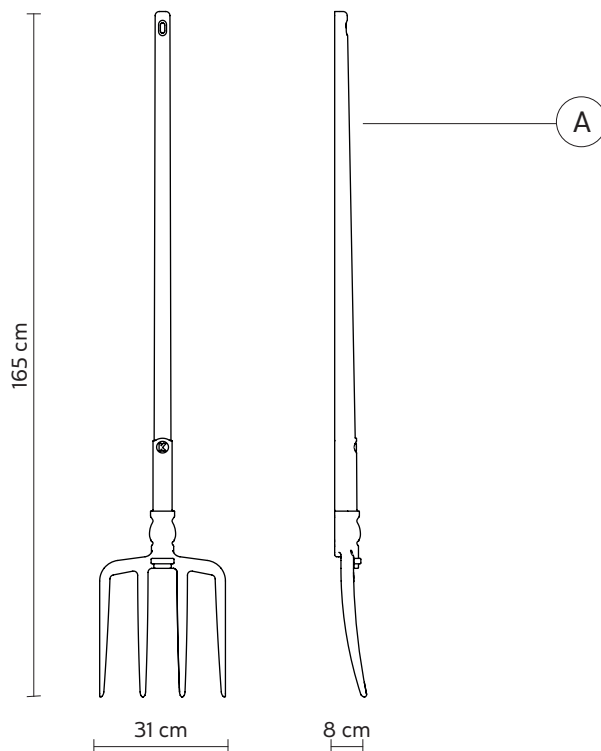

## COLLECTION

available also as: outdoor version

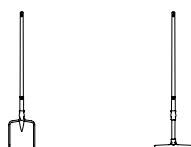

HP145 2P INT HP145 3R INT