

CELL table lamp

Matteo Ugolini design

year 2018

DATA SHEET - CT612 AM EXT

LAMP "A"

material steel inox
colour lacquered
glossy bronze



DIFFUSER "B"

material methacrylate
(PMMA)
colour white

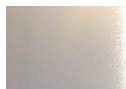

ELECTRICAL CABLE "C"

colour black



ELECTRICAL SYSTEM

socket E27
source 1 x max 23W
energy class from E to A++

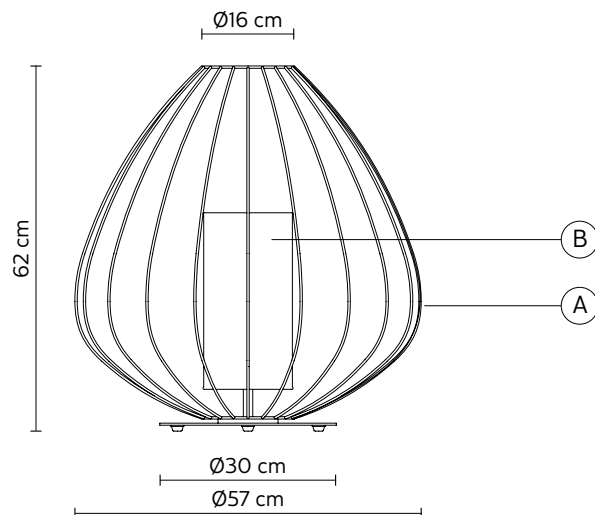

PACKAGING

n° cartons 1
net weight/kg 7,9
gross weight/kg 10
packaging/cm 63x63x67

LIGHT EMISSION

unidirectional

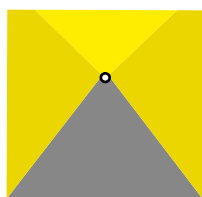

COMPLIANT WITH

IEC 60598-1:2014
EN 60598-1:2015



degree of protection IP65
bulb equipped

1xE27 LED
10W, 900lumen - 2700K
class A+

COLLECTION

also available suspension lamp version and in white color



CT612 AM INT

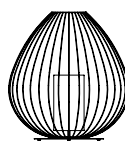

HP613 BM INT

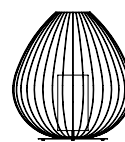

HP613 BM EXT



CT614 CM INT

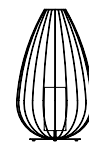

HP615 DM INT

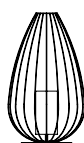

HP615 DM EXT

CELL table lamp

Matteo Ugolini design

year 2018

DATA SHEET - CT612 AM INT

LAMP "A"

material stainless steel
colour lacquered
glossy bronze



LAMPSHADE "B"

material linen
colour white



ELECTRICAL CABLE "C"

colour transparent



ELECTRICAL SYSTEM

socket E27
source 1 x max 52W
energy class from E to A++

PACKAGING

n° cartons 1
net weight/kg 5
gross weight/kg 6,5
packaging/cm 62x62x65

LIGHT EMISSION

unidirectional

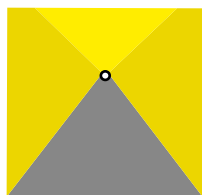

direct
filtered
indirect
absence

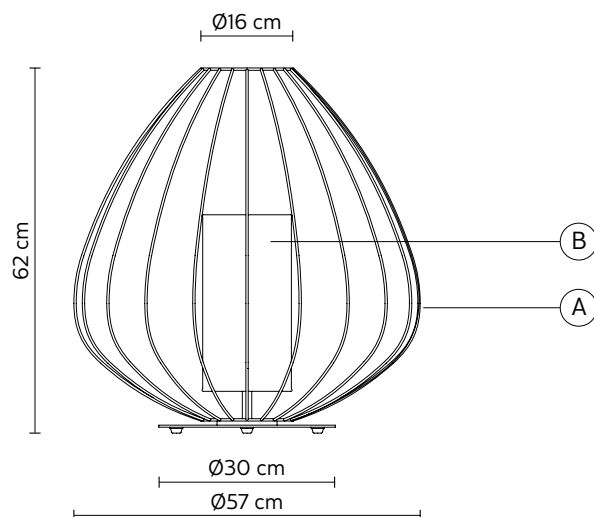

COMPLIANT WITH

IEC 60598-1:2014
EN 60598-1:2015



degree of protection IP20
bulb not provided

COLLECTION

also available suspension lamp version and in white color

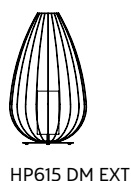
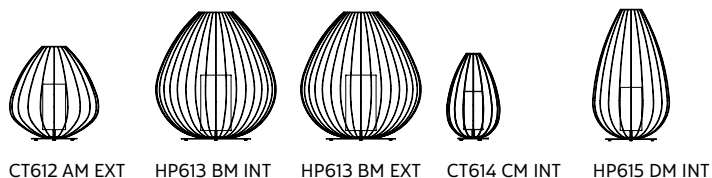

CELL table lamp

Matteo Ugolini design

year 2018

DATA SHEET - **CT614 CM INT**

LAMP "A"

material stainless steel
colour lacquered
glossy bronze



LAMPSHADE "B"

material linen
colour white



ELECTRICAL CABLE "C"

colour transparent



ELECTRICAL SYSTEM

socket E27
source 1 x max 52W
energy class from E to A++

PACKAGING

n° cartons 1
net weight/kg 2,5
gross weight/kg 3,5
packaging/cm 36x37x64

LIGHT EMISSION

unidirectional

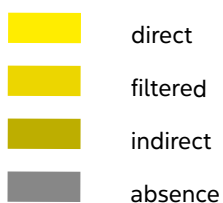
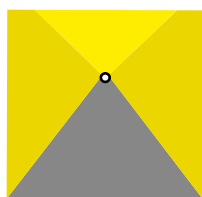

COMPLIANT WITH

IEC 60598-1:2014
EN 60598-1:2015



degree of protection IP20
bulb not provided

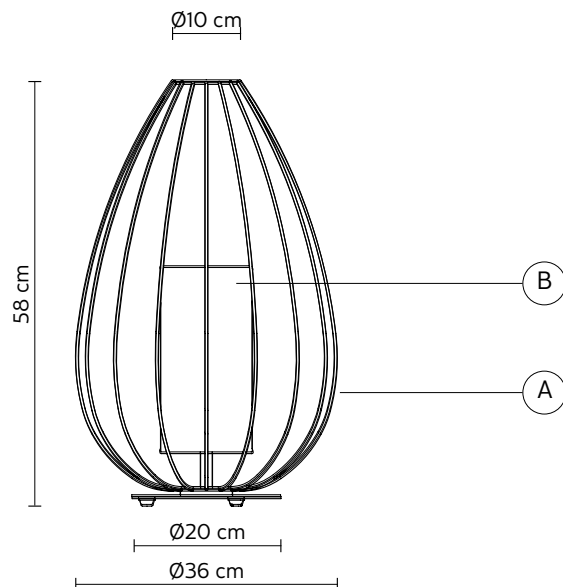

COLLECTION

also available suspension lamp version and in white color

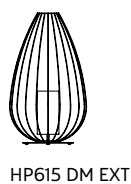
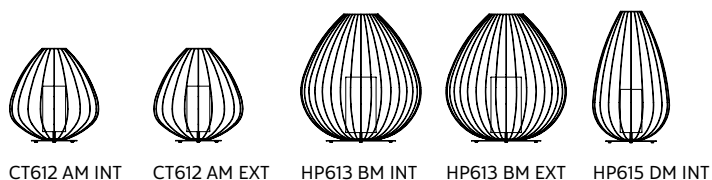

CELL floor lamp

Matteo Ugolini design

year 2018

DATA SHEET - HP613 BM EXT

LAMP "A"

material steel inox
colour lacquered
glossy bronze



DIFFUSER "B"

material methacrylate
(PMMA)
colour white

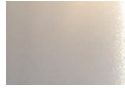

ELECTRICAL CABLE "C"

colour black



ELECTRICAL SYSTEM

socket E27
source 1 x max 23W
energy class from E to A++

PACKAGING

n° cartons 1
net weight/kg 13
gross weight/kg 19
packaging/cm 94x94x94

LIGHT EMISSION

unidirectional

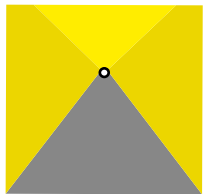

 direct
 filtered
 indirect
 absence

COMPLIANT WITH

IEC 60598-1:2014
EN 60598-1:2015



degree of protection IP65
bulb equipped

1xE27 LED
10W, 900lumen - 2700K
class A+

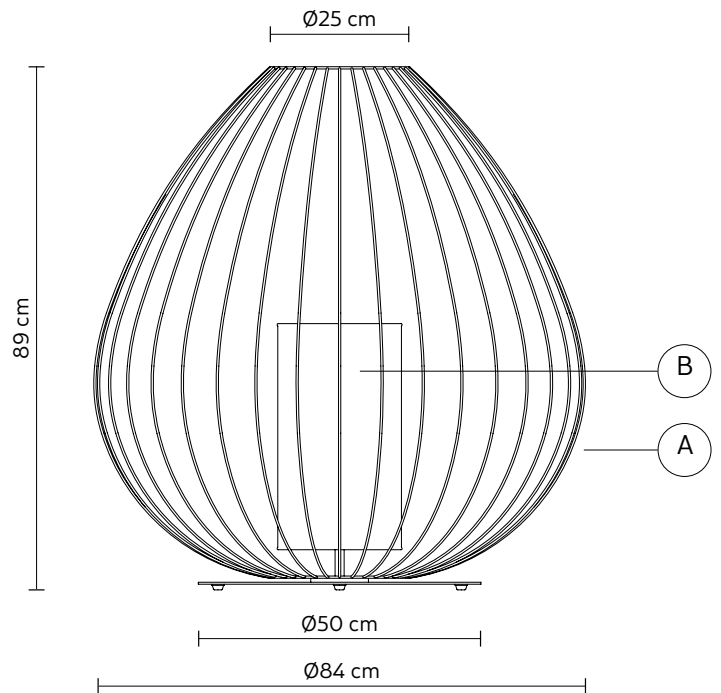

COLLECTION

also available suspension lamp version and in white color

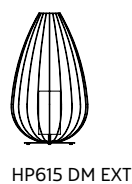
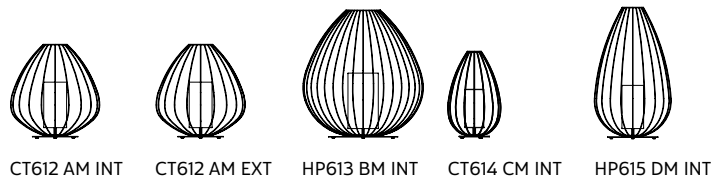

CELL floor lamp

Matteo Ugolini design

year 2018

DATA SHEET - HP613 BM INT

LAMP "A"

material stainless steel
colour lacquered
glossy bronze



LAMPSHADE "B"

material linen
colour white



ELECTRICAL CABLE "C"

colour transparent



ELECTRICAL SYSTEM

socket E27
source 1 x max 70W
energy class from E to A++

PACKAGING

n° cartons 1
net weight/kg 13
gross weight/kg 16
packaging/cm 94x94x94

LIGHT EMISSION

unidirectional

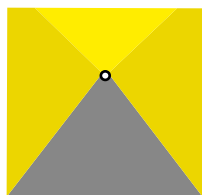

direct
filtered
indirect
absence

COMPLIANT WITH

IEC 60598-1:2014
EN 60598-1:2015



degree of protection IP20
bulb not provided

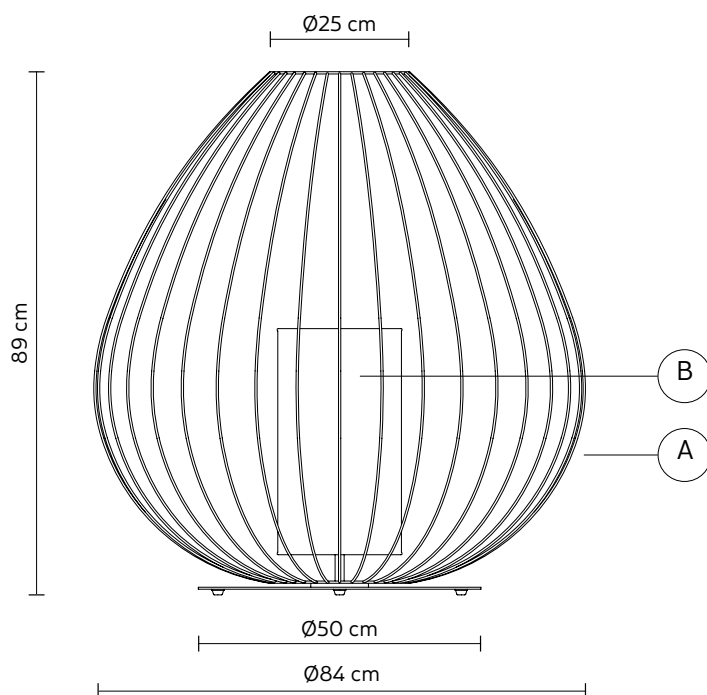

COLLECTION

also available suspension lamp version and in white color

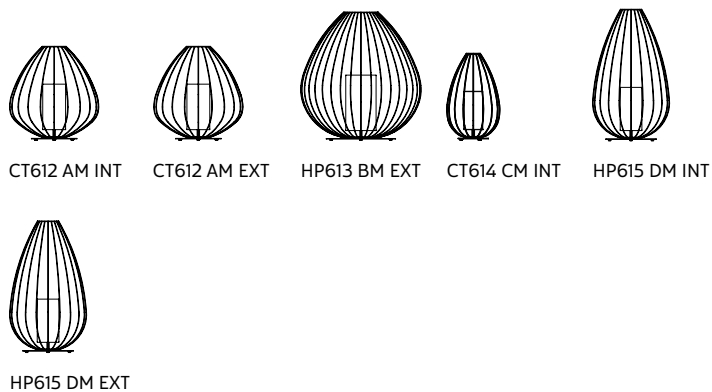

CELL floor lamp

Matteo Ugolini design

year 2018

DATA SHEET - HP615 DM EXT

LAMP "A"

material steel inox
colour lacquered
glossy bronze



DIFFUSER "B"

material methacrylate
(PMMA)
colour white

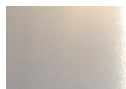

ELECTRICAL CABLE "C"

colour black



ELECTRICAL SYSTEM

socket E27
source 1 x max 23W
energy class from E to A++

PACKAGING

n° cartons 1
net weight/kg 8
gross weight/kg 10
packaging/cm 57x57x93

LIGHT EMISSION

unidirectional

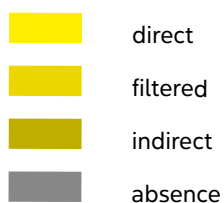
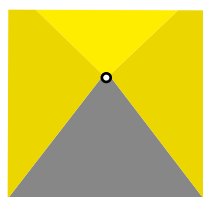

COMPLIANT WITH

IEC 60598-1:2014
EN 60598-1:2015



degree of protection IP65
bulb equipped

1xE27 LED
10W, 900lumen - 2700K
class A+

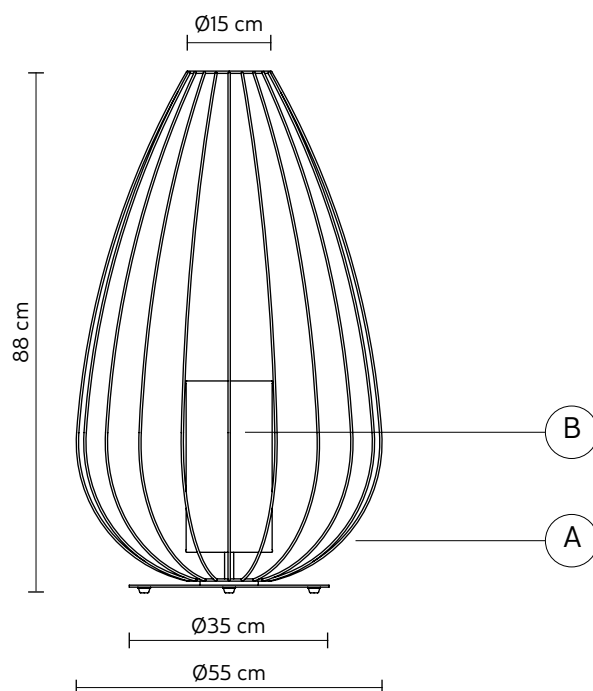

COLLECTION

also available suspension lamp version and in white color

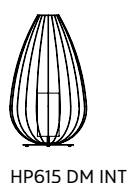

CELL floor lamp

Matteo Ugolini design

year 2018

DATA SHEET - HP615 DM INT

LAMP "A"

material stainless steel
colour lacquered
glossy bronze



LAMPSHADE "B"

material linen
colour white



ELECTRICAL CABLE "C"

colour transparent



ELECTRICAL SYSTEM

socket E27
source 1 x max 52W
energy class from E to A++



PACKAGING

n° cartons 1
net weight/kg 7,5
gross weight/kg 9,5
packaging/cm 57x57x93

LIGHT EMISSION

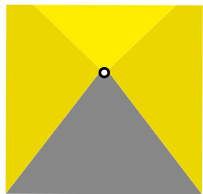
unidirectional



 direct
 filtered
 indirect
 absence

COMPLIANT WITH

IEC 60598-1:2014
EN 60598-1:2015



degree of protection IP20
bulb not provided

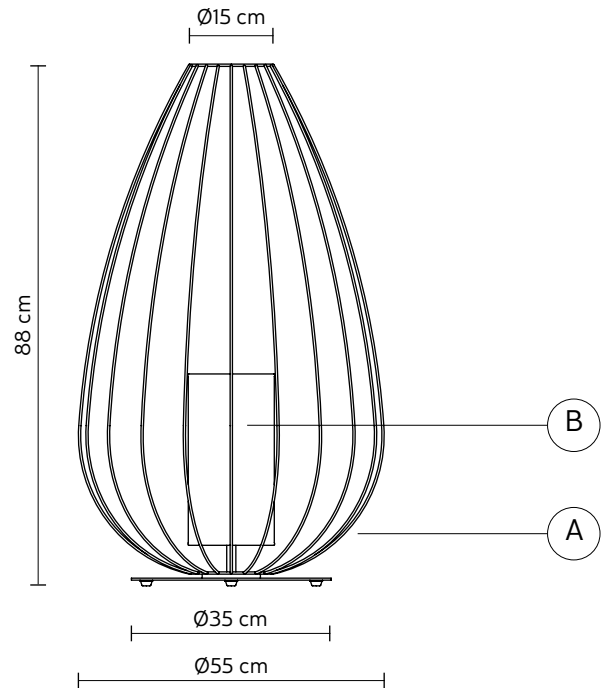

COLLECTION

also available suspension lamp version and in white color

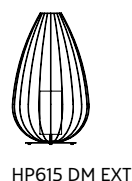

CELL table lamp

Matteo Ugolini design

year 2012

TECHNICAL SHEET - M612-EXT

STRUCTURE "A"

material	steel inox	
colour	glossy white	

SHADE "B"

material	Pmma	
colour	white	

ELECTRICAL CABLE "C"

material	neoprene	
colour	green	

ELECTRICAL SYSTEM

socket	E27
source	max 1x23w
energy class	from E to A++

PACKAGING

nr. of collis	1
net weight/kg	7,9
gross weight/kg	10
packaging/cm	63x63x67

EMISSION OF LIGHT

one-directional



CERTIFICATION

IEC 60598-1:2008
EN 60598-1:2008 + A11:2009



IP rate
bulb IP65
class A equipped

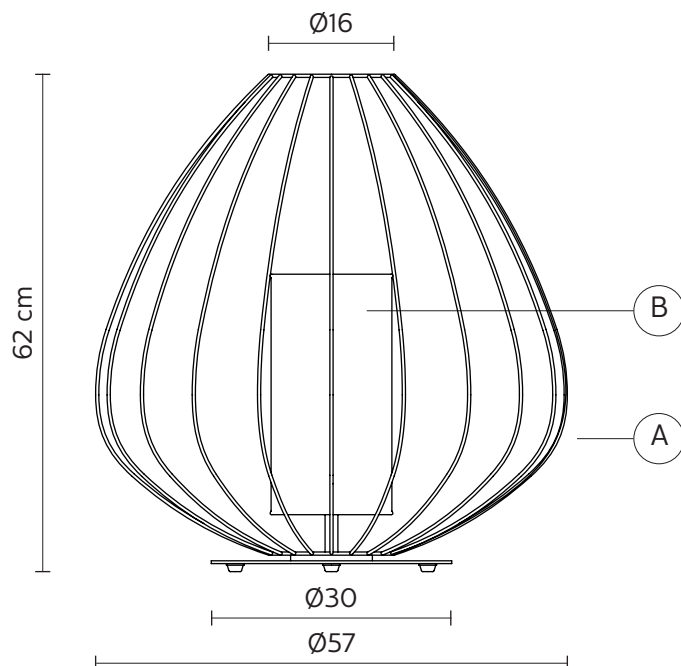

COLLECTION

available also as: suspension (in/outdoor)

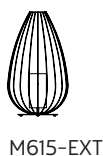

CELL table lamp

Matteo Ugolini design

year 2011

TECHNICAL SHEET - M612B

STRUCTURE "A"

material	steel inox	
colour	glossy white	

SHADE "B"

material	linen	
colour	white	

ELECTRICAL CABLE "C"

material	PVC	
colour	transparent	

ELECTRICAL SYSTEM

socket	E27
source	max 1x52w
energy class	from E to A++

PACKAGING

nr. of collis	1
net weight/kg	5
gross weight/kg	6,5
packaging/cm	62x62x65

EMISSION OF LIGHT

one-directional

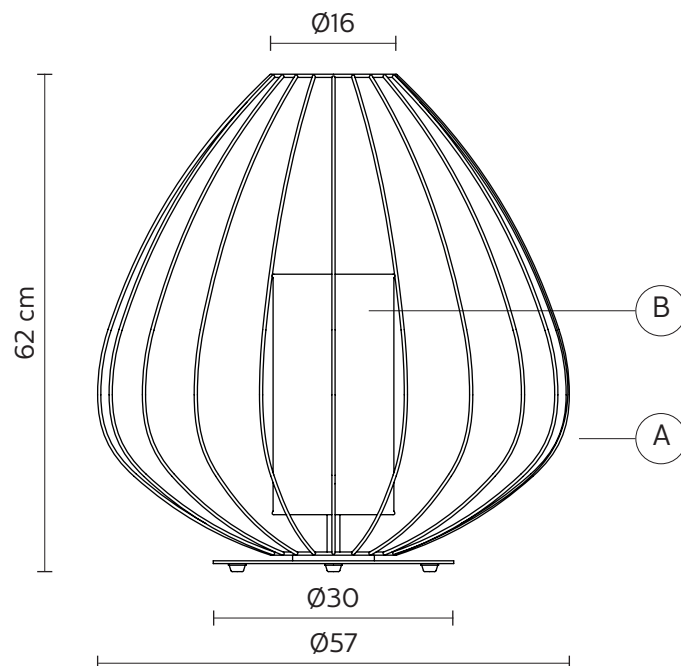

CERTIFICATION

IEC	60598-1:2008
EN	60598-1:2008 + A11:2009



IP rate	IP20
bulb	not provided

COLLECTION

available also as: suspension (in/outdoor)

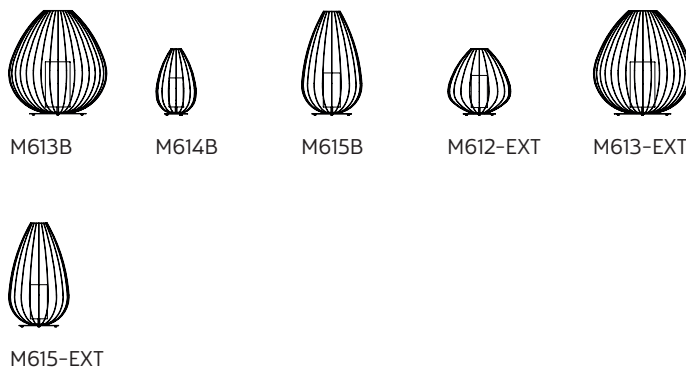

CELL floor lamp

Matteo Ugolini design

year 2011

TECHNICAL SHEET - M613B

STRUCTURE "A"

material	steel inox	
colour	glossy white	

SHADE "B"

material	linen	
colour	white	

ELECTRICAL CABLE "C"

material	PVC	
colour	transparent	

ELECTRICAL SYSTEM

socket	E27
source	max 1x70w
energy class	from E to A++

PACKAGING

nr. of collis	1
net weight/kg	13
gross weight/kg	16
packaging/cm	94x94x94

EMISSION OF LIGHT

one-directional

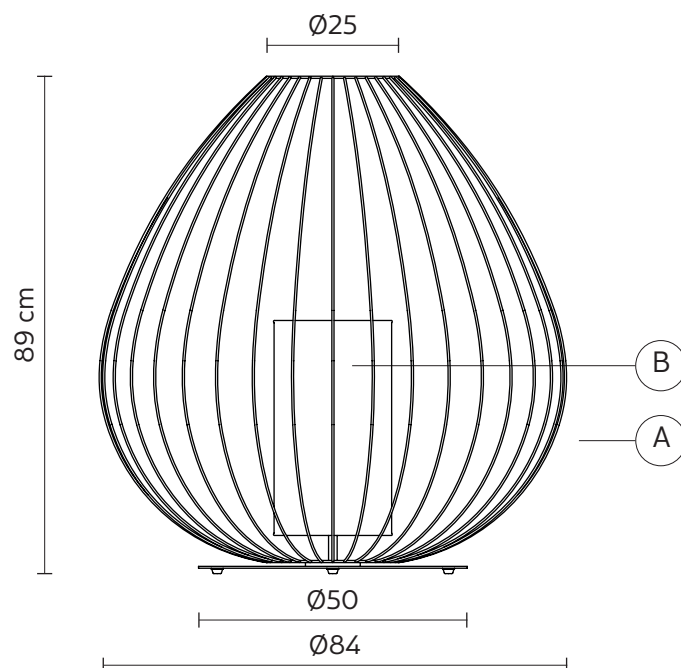

CERTIFICATION

IEC 60598-1:2008
EN 60598-1:2008 + A11:2009



IP rate IP20
bulb not provided

COLLECTION

available also as: suspension (in/outdoor)

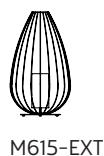

CELL floor lamp

Matteo Ugolini design

year 2011

TECHNICAL SHEET - M615B

STRUCTURE "A"

material	steel inox	
colour	glossy white	

SHADE "B"

material	linen	
colour	white	

ELECTRICAL CABLE "C"

material	PVC	
colour	transparent	

ELECTRICAL SYSTEM

socket	E27
source	max 1x52w
energy class	from E to A++





PACKAGING

nr. of collis	1
net weight/kg	7,5
gross weight/kg	9,5
packaging/cm	57x57x93

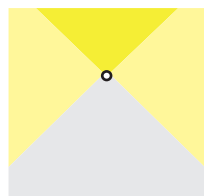
EMISSION OF LIGHT

one-directional



	direct
	filtered
	indirect
	none

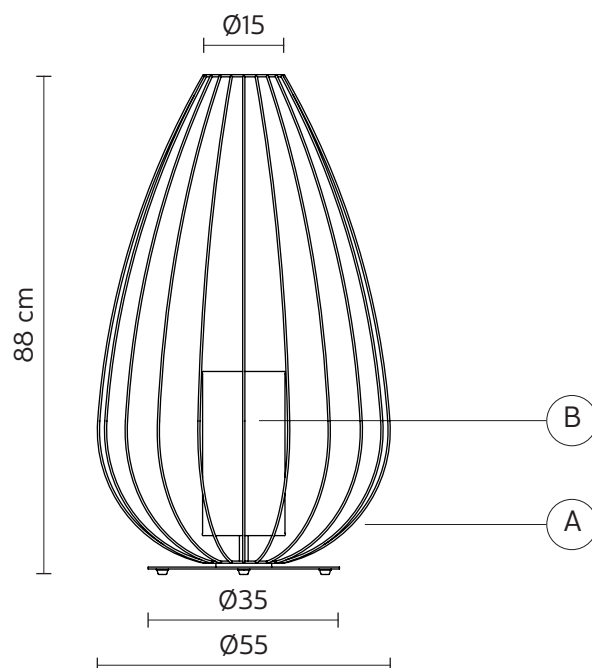

CERTIFICATION

IEC	60598-1:2008
EN	60598-1:2008 + A11:2009



IP rate	IP20
bulb	not provided

COLLECTION

available also as: suspension (in/outdoor)

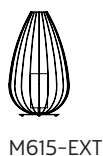

CELL floor lamp

Matteo Ugolini design

year 2012

TECHNICAL SHEET - M615-EXT

STRUCTURE "A"

material	steel inox	
colour	glossy white	

SHADE "B"

material	Pmma	
colour	white	

ELECTRICAL CABLE "C"

material	neoprene	
colour	green	

ELECTRICAL SYSTEM

socket	E27
source	max 1x23w
energy class	from E to A++





PACKAGING

nr. of collis	1
net weight/kg	8
gross weight/kg	10
packaging/cm	57x57x93

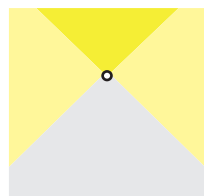
EMISSION OF LIGHT

one-directional



	direct
	filtered
	indirect
	none

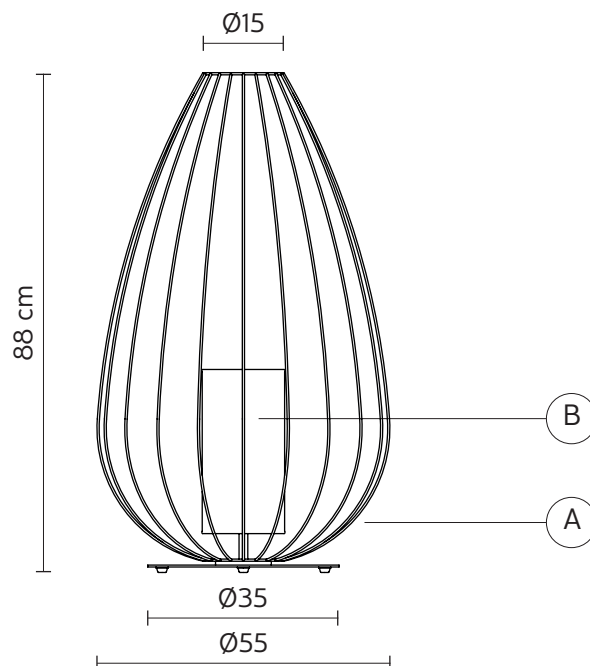

CERTIFICATION

IEC	60598-1:2008
EN	60598-1:2008 + A11:2009



IP rate	IP65
bulb	class A equipped

COLLECTION

available also as: suspension (in/outdoor)



CELL table lamp

Matteo Ugolini design

year 2009/2012

TECHNICAL SHEET - M614B

STRUCTURE "A"

material	steel inox	
colour	glossy white	

SHADE "B"

material	linen	
colour	white	

ELECTRICAL CABLE "C"

material	PVC	
colour	transparent	

ELECTRICAL SYSTEM

socket	E27
source	max 1x52w
energy class	from E to A++





PACKAGING

nr. of collis	1
net weight/kg	2,5
gross weight/kg	3,5
packaging/cm	36x37x64

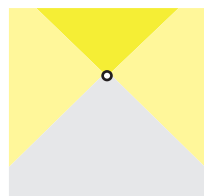
EMISSION OF LIGHT

one-directional



	direct
	filtered
	indirect
	none

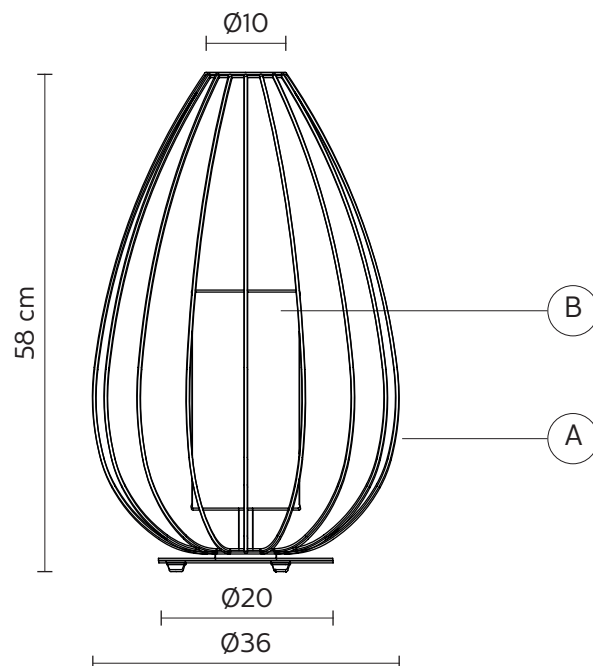

CERTIFICATION

IEC	60598-1:2008
EN	60598-1:2008 + A11:2009



IP rate	IP20
bulb	not provided

COLLECTION

available also as: suspension (in/outdoor)

