

TABLES

Pan Coupé

Jules Wabbes



Jules Wabbes is an icon of Belgian design in the 1950s till 1970s. His designs have become a Belgian heritage and the originals are collectibles. The Pan Coupé was reissued by Bulo in 2010. The organic and graceful base is in cast aluminium or solid bronze and arches upwards to support a high quality top in solid cross-cut wood, veneer, HPL, marble or blue stone.

Met een onderstel uit geanodiseerd gietaluminium of massief brons behoort de tafel Pan Coupé tot de meest fundamentele creaties van Jules Wabbes, Belgisch design icoon in de jaren '50 tot '70. Het dikke blad uit kops hout of andere natuurlijke materialen zoals marmer, blauwe steen of fineer wordt gedragen door de vijf rijzig slanke armen van de tulpvormige centrale voet. Het tafelblad kan cirkelvormig of met afgesneden zijde.

De la fonte d'aluminium, du bronze massif et une évidence très Jules Wabbes, la table Pan Coupé s'inscrit dans l'histoire. Elancés les arcs sont tendus à l'extrême vers le plateau en marbre, pierre bleue, placages de bois ou bois debout. La forme du plateau est circulaire ou « pan coupé ».



TABLES

Pan Coupé

TECHNICAL SHEET

MEETING TABLE - CIRCULAR

H = 750

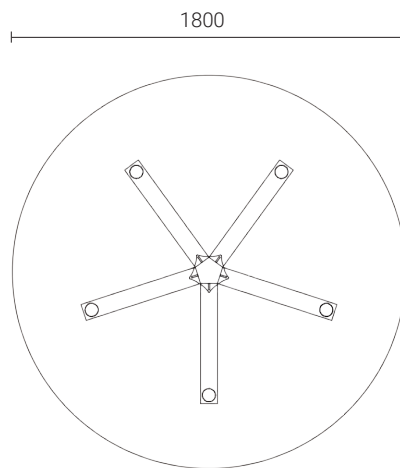
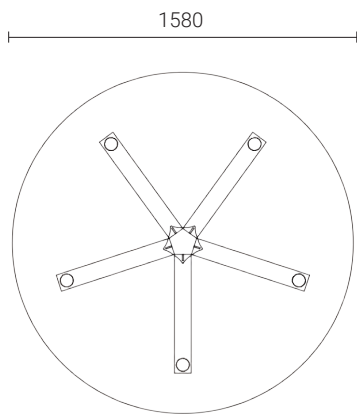

MEETING TABLE - CANTED

H = 750

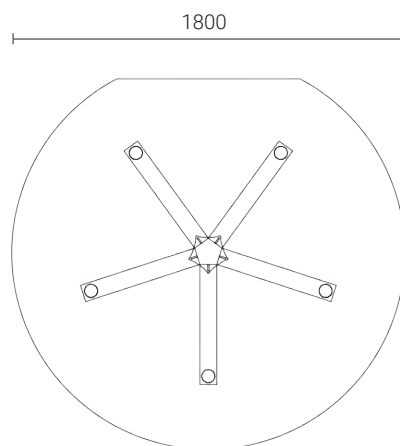
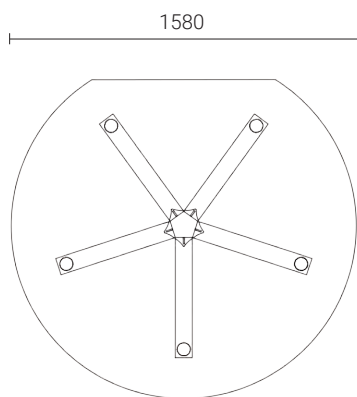

COLORS & MATERIALS

TABLE TOP

HPL MULTIPLY COATED (Only 1580 dia.)

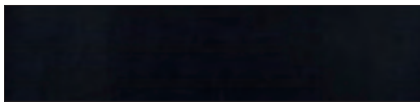

Black



Red



White



Pearl Grey

NATURAL STONE



Carrara Marble



Zimbabwe Granite



Belgian Blue Stone

TABLE BASE



Anodised Aluminium



Bronze

WOOD



Walnut Veneer

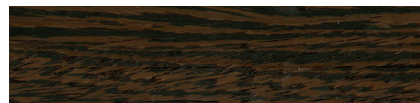

Wengé Veneer



Fumed Oak Veneer



White Beech Veneer

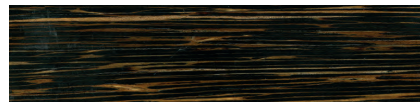

Palm Veneer



Cross Cut Cherry



Cross Cut Wengé